



City of Coquitlam

**Contract Documents  
79058**

**Clarke & Glenayre and  
Lougheed & Woolridge  
Intersection Improvements**



# ***Table of Contents***

## Contract No. 79058

### Clarke & Glenayre and Loughheed & Woolridge Intersection Improvements

#### Project Construction Documents

##### Table of Contents

The complete **Project Construction Documents** consist of the following parts:

<b>1. Standard Documents – supplied</b>	<b>Page</b>
Table of Contents .....	TC 1 to TC 2
Invitation to Tender .....	IN 1 to IN 3
Instruction to Tenderers	
▪ Table of Contents .....	IT 1
▪ Instructions to Tenderers .....	IT 2 to IT 13
Form of Tender, including	
▪ Form of Tender Summary .....	FT 1
▪ Form of Tender .....	FT 2 to FT 5
▪ Appendix 1 – Schedule of Quantities and Unit Prices .....	FT 6 to FT 8
▪ Appendix 2 – Preliminary Construction Schedule .....	FT 9
▪ Appendix 3 – Experience of Superintendent .....	FT 10
▪ Appendix 4 – Comparable Work Experience .....	FT 11
▪ Appendix 5 – Subcontractors .....	FT 12
▪ Appendix 6 – Bid Bond .....	FT 13
▪ Appendix 7 – Certificate of Compliance for Contract Insurance .....	FT 14
Agreement between Owner and Contractor .....	AGT 1 to AGT 4
Schedule 1 – Schedule of Contract Documents .....	AGT 5
Schedule 2 – List of Drawings .....	AGT 6
Supplementary General Conditions – Table of Contents .....	SGC 1 to SGC 2
▪ Supplementary General Conditions, including .....	SGC 3 to SGC 25
▪ Appendices:	
▪ Appendix I Performance Bond .....	SGC 19 to SGC 20
▪ Appendix II labour and Material Payment Bond .....	SGC 21 to SGC 23
▪ Appendix III Certificate of Insurance .....	SGC 24
▪ Appendix IV Prime Contractor Designation .....	SGC 25

**Table of Contents**

Supplementary Contract Specifications ..... SS 1 to SS 69

Appendix A – Traffic Management Detail Specifications..... TMP 1 to TMP 11

Appendix B – Archaeological Chance Find Procedures ..... ACF 1 to ACF 19

Appendix C – As-built Records ..... ASB 1

Appendix D – Standard Detail Drawings..... SDD 1 to SDD 3

Appendix E – Irrigation As-built Record Drawings ..... IRR 1

Contract Drawings ..... Under Separate Cover

**2. Standard Documents – not supplied**

- i) (available in the “MMCD – General Conditions, Specifications and Standard Detail Drawings”)
  - Instructions to Tenderers
  - General Conditions
    - Schedule 17.5.3 – Letter Agreement with Referee
    - Flow Chart – Changes and Extra Work
    - Flow Chart – Dispute Resolution
  - Specifications
  - Standard Detail Drawings
- ii) City of Coquitlam Supplementary Specifications for Contract Documents

# ***Invitation to Tender***



## INVITATION TO TENDER

DATE OF ISSUE: **May 14, 2026**

*We acknowledge with gratitude and respect that the name Coquitlam was derived from the hən̓q̓əmi̓n̓əh̓ word kʷikwə́ləm (kwee-kwuh-tlum) meaning “Red Fish Up the River”. The City is honoured to be located on the kʷikwə́ləm (Kwikwetlem) traditional and ancestral lands, including those parts that were historically shared with the s̓q̓əciyaʔ təməxʷ (Katzie), and other Coast Salish Peoples.*

### **Tender No. 79058**

### **Clarke & Glenayre and Lougheed & Woolridge Intersection Improvements**

The City of Coquitlam invites tenders for **Contract 79058 - Clarke & Glenayre and Lougheed & Woolridge Intersection Improvements**, generally consisting of the following, but not limited to:

- Clarke Rd & Glenayre Drive  
Conversion of protected left turn signal phasing to protected only; safety improvement to address deficient vertical sight lines of South Bound vehicles
- Lougheed Hwy & Woolridge Connector  
Conversion of left turn half signal to two-stage pedestrian signal; provide safe highway crossing for pedestrians and bikes; Concrete works; and
- Other miscellaneous and incidental works as further described in the Contract Documents.

Tender Documents and Drawings are available for downloading from the City of Coquitlam website: [www.coquitlam.ca/BidOpportunities](http://www.coquitlam.ca/BidOpportunities)

Printing of Tender documents and drawings is the sole responsibility of the Tenderers.

Tenders submitted must be accompanied by a copy of the original specified 10% Bid Bond and will be received:

**On or Before 2:00 pm local time**  
**June 4, 2026**  
("Closing Date and Time")

### **Addenda**

**Tenderers are required to check the City's website for any updated information, issued before the Closing Date at: [www.coquitlam.ca/BidOpportunities](http://www.coquitlam.ca/BidOpportunities). Where in its sole discretion it considers it to be necessary or desirable, the City may issue Addenda to amend any portion of the Contract Documents.**

Any changes to the Tender documentation will be issued by means of written Addenda and posted on the City's website and will form part of the Tender. No amendment of any kind to the Tender is effective unless it is posted in a formal written Addendum on the City website. Upon submitting a Tender, Tenderers will be deemed to have received notice of all Addenda that are posted on the City's website and deemed to have considered the information for inclusion in the Tender submitted.

The City does not retain a bidder's list or bidder's registry. Tenderers are encouraged to register as plan takers and may view the Tender Documents and Drawings by contacting the Vancouver Regional Construction Association (VRCA), website: [www.my.vrca.ca](http://www.my.vrca.ca), ph: 604-294-3766, or email at [vrca@vrca.ca](mailto:vrca@vrca.ca), quoting the Coquitlam Tender Reference Number.

Should there be any discrepancy in the documentation provided, the City's original file copy shall prevail.

Tenders shall remain open for acceptance for 60 days following the submission Closing Date.

The City reserves the right to accept or reject any or all Tenders and the lowest or any Tender may not necessarily be accepted. The City also reserves the right to cancel any request for Tender at any time without recourse by the Tenderer.

The City, prior to award of any Tender, may negotiate with the Tenderer presenting the lowest price compliant Tender, for changes in the Work, materials, specifications or conditions without having any duty or obligation to advise any other Tenderers or to allow them to modify their Tenders, and the City will have no liability to any Tenderer as a result of such negotiations or modifications.

The City will not be responsible for any costs incurred by the Tenderer in preparing the Tender.

Procurement of goods and services is conducted in accordance with Chapter 5 of the Canadian Free Trade Agreement (CFTA) and the New West Partnership Trade Agreement (NWPTA).

M. Pain  
Manager Procurement

# ***Instructions to Tenderers***

**Tender 79058**

**Clarke & Glenayre and Loughheed & Woolridge Intersection Improvements**

**INSTRUCTIONS TO TENDERERS**

<b>TABLE OF CONTENTS</b>	<b>Page</b>
<b>1 Introduction.....</b>	<b>IT 2</b>
<b>2 Tender Documents.....</b>	<b>IT 2 to 3</b>
<b>3 Submission of Tenders.....</b>	<b>IT 3 to 4</b>
<b>4 Additional Instructions to Tenderers.....</b>	<b>IT 4 to 5</b>
<b>5 Tender Requirements .....</b>	<b>IT 6 to 7</b>
<b>6 Qualifications, Modifications, Alternative Tender .....</b>	<b>IT 7</b>
<b>7 Approved Equals.....</b>	<b>IT 7</b>
<b>8 Inspection of the Place of the Work.....</b>	<b>IT 8</b>
<b>9 Interpretation of Contract Documents .....</b>	<b>IT 8</b>
<b>10 Prices .....</b>	<b>IT 8 to 9</b>
<b>11 Taxes.....</b>	<b>IT 9</b>
<b>12 Amendment of Tenders .....</b>	<b>IT 9 to 10</b>
<b>13 Duration of Tenders .....</b>	<b>IT 10</b>
<b>14 Qualifications of Tenders .....</b>	<b>IT 10</b>
<b>15 Award.....</b>	<b>IT 10 to 12</b>
<b>16 Subcontractors .....</b>	<b>IT 12 to 13</b>
<b>17 Optional Work.....</b>	<b>IT 13</b>

## INSTRUCTIONS TO TENDERERS

(FOR USE WHEN UNIT PRICES FORM THE BASIS OF PAYMENT - TO BE USED ONLY WITH THE GENERAL CONDITIONS AND OTHER STANDARD DOCUMENTS OF THE UNIT PRICE MASTER MUNICIPAL CONSTRUCTION DOCUMENTS.)

### The City of Coquitlam

*Contract:* **Clarke & Glenayre and Lougheed & Woolridge Intersection Improvements**

*Reference No.* **79058**

- 1.0 Introduction**
- 1.1 These Instructions apply to and govern the preparation of tenders for this *Contract*. The *Contract* is generally for the following work:
- Clarke Rd & Glenayre Drive  
Conversion of protected left turn signal phasing to protected only; safety improvement to address deficient vertical sight lines of South Bound vehicles
  - Lougheed Hwy & Woolridge Connector  
Conversion of left turn half signal to two-stage pedestrian signal; provide safe highway crossing for pedestrians and bikes; Concrete works
  - Other miscellaneous and incidental works as further described in the Contract Documents.
- 1.2 All inquiries regarding this Tender are to be submitted in writing referencing the **Tender Name and Number** sent to:
- E-mail** [bid@coquitlam.ca](mailto:bid@coquitlam.ca)
- The deadline for inquiries is **12:00 PM** local time, **Monday, June 1, 2026**.  
**INQUIRIES RECEIVED AFTER THIS DATE AND TIME MAY NOT RECEIVE A RESPONSE.**
- 2.0 Tender Documents**
- 2.1 The Tender Documents which a Tenderer should review to prepare a Tender consist of all of the *Contract Documents* listed in Schedule 1 entitled "Schedule of Contract Documents". Schedule 1 is attached to the Agreement which is included as part of the Tender Package. The *Contract Documents* include the drawings listed in Schedule 2 to the Agreement, entitled "**List of Contract Drawings**".
- 2.2 A portion of the Contract Documents are included by reference. Copies of these documents have not been included with the tender package. These documents are the General Conditions, Specifications and Standard Detail Drawings. They are those contained in the publication entitled "Master Municipal Construction Documents - General Conditions, Specifications and

Standard Detail Drawings". Refer to Schedule 1 to the Agreement or, if not specified in Schedule 1, then the applicable edition shall be the most recent edition as of the date of the *Tender Closing Date*. All sections of this publication are by reference included in the Contract Documents.

2.3 Any additional information made available to Tenderers prior to the Tender Closing Time by the Owner or representative of the Owner, such as geotechnical reports or as-built plans, which is not expressly included in Schedule 1 or Schedule 2 to the Agreement, is not included in the Contract Documents. Such additional information is made available only for the assistance of Tenderers who must make their own judgments about its reliability, accuracy, completeness and relevance to the *Contract*, and neither the Owner nor any representative of the Owner gives any guarantee or representation that the additional information is reliable, accurate, complete or relevant.

**3.0 Submission of Tenders**

3.1 Tenders must be submitted on the Tender Form provided, accompanied by a copy of the original 10% Bid Bond quoting the Tender Name and Number, and be uploaded to the City's file transfer website.

Tenders must be received on or before:

***Tender Closing Time:* 2:00 p.m. local time**

***Tender Closing Date:* June 4, 2026**

For the purpose of the Tender submission, digital copies of original documents and signatures sent electronically are accepted. Original documents are required upon request by the City.

**Instructions for Tender Submission**

3.2 **Tender submissions are to be consolidated into one (1) .pdf file and uploaded electronically through QFile, the City's file transfer service accessed at website: <https://qfile.coquitlam.ca/filedrop/purchasing>**

- 1. In the "From" field enter:** Tenderers email address
- 2. In the "Subject" field enter:** Tender Name
- 3. In the "BID Number" field enter:** Tender Number
- 4. In the "Type" field enter:** **New** if this is a new submission or **Update** if this is an updated submission
- 5. Add consolidated Tender files in Adobe PDF format, and Appendix 1 in Microsoft Excel XLS format, and Send** (ensure your web browser remains open until you receive a files sent message. You will also receive an email from QFile confirming the submission)

**Tenderers are responsible to allow ample time to complete the Tender submission process. If assistance is required, phone 604-927-3037.**

- 3.3 Tenders submitted shall be deemed to be received when displayed as a new email in the in-box of the above email address. The City will not be responsible for any delay or for any Tenders not received for any reason, including technological delays or issues by either party's network or email program, and the City will not be liable for any damages associated with Tenders not received.
- 3.4 The City reserves the right to accept late Tenders to allow for technological delays. The City also reserves the right to accept Tenders by email: [bid@coquitlam.ca](mailto:bid@coquitlam.ca).
- BIDS RECEIVED IN-PERSON, BY COURIER, OR BY FAX WILL NOT BE ACCEPTED.**
- 3.5 Tenders will not be opened in public. The unevaluated results will be forwarded to participants by email.
- 3.6 Tender submissions are subject to the Freedom of Information and Protection of Privacy Act and contents may be disclosed if required to do so, pursuant to the Act.

**4.0 Additional  
Instructions to  
Tenderers**

Additional Instructions to Tenderers

**Obtaining  
Documents**

- 4.1 The following documents which are referred to and form part of the Contract Document package may be obtained as follows:
- Copies of the Master Municipal Construction Documents Volume II (2009), General Conditions, Specifications and Standard Detail Drawings are available separately from:  
  
Support Services Unlimited  
Suite 102  
211 Columbia Street  
Vancouver, B.C. V6A 2R5  
Tel: 604-681-0295  
Fax: 604-305-0424
  - Copies of the City of Coquitlam Supplementary Specifications and Detailed Drawings to the MMCD 2009 Edition are available for viewing and downloading off the City of Coquitlam website: [Supplementary Specifications and Detailed Drawings to MMCD](#)

**Test  
Excavations**

- 4.2 Prior to the excavation of test holes on road allowances or privately owned property the Tenderer shall obtain permission from the Municipality or Owner of the property and comply with their requirements for restoration of disturbed surfaces and utilities. Failure to comply with Municipal by-laws restricting this practice may result in prosecution of the offending party.

- |   |      |   |
|---|------|---|
| <b>Business License</b>                     | 4.3  | The successful Tenderer shall provide evidence of a City of Coquitlam Business License or Tri-Cities Inter-Municipal Business License prior to commencement of work or supply of materials. For more information, contact Business License Division Ph: 604-927-3085 or apply online at website: <a href="#">City of Coquitlam Business License</a>   |
| <b>No Claim</b>                             | 4.4  | Except as expressly and specifically permitted in these Instructions to Tenderers, no Tenderer shall have any claim for any compensation of any kind whatsoever, as a result of participating in this Tender, including accepting a non-compliant bid and by submitting a Tender, each Tenderer shall be deemed to have agreed that it has no claim.  |
| <b>No Cost</b>                              | 4.5  | The City will not under any circumstances be responsible for any costs incurred by the Tenderer in preparing the Tender.  |
| <b>Right to Accept or Reject any Tender</b> | 4.6  | <p>The City reserves the right to accept or reject any or all Tenders and the lowest or any Tender may not necessarily be accepted. In its sole discretion, the City may reject or retain for its consideration, tenders which are nonconforming because they do not contain the content or form required by the instructions to tenderers or for failure to comply with the process for submission set out in these instructions to tenderers.</p> <p>The City specifically reserves the right to reject all Tenders if none is considered to be satisfactory and, in that event, at its option, to call for additional Tenders.</p> |
| <b>Negotiation</b>                          | 4.7  | The City, prior to award of any Tender, may negotiate with the Tenderer presenting the lowest price compliant Tender, for changes in the Work, materials, specifications or conditions without having any duty or obligation to advise any other Tenderers or to allow them to modify their Tenders, and the City will have no liability to any Tenderer as a result of such negotiations or modifications.   |
| <b>Cancellation of Tender</b>               | 4.8  | The City reserves the right to cancel any request for Tender at any time without recourse by the Tenderer. The City has the right to not award this work for any reason including choosing to complete the work with the City's own forces.   |
| <b>Conflict of Interest</b>                 | 4.9  | Tenderers shall disclose any actual or potential conflicts of interest and existing business relationships it may have with the City, their elected or appointed officials or employees.  |
| <b>Collusion</b>                            | 4.10 | Tenderers will not discuss or communicate with one another in regards to the preparation of their Tenders. Each Tenderer will ensure that its participation in the Tender process and that of its team members is conducted without collusion or fraud. Failure to comply with this requirement may lead to disqualification without further notice or warning.   |

**Instruction to  
Tenderers –  
Part II**

Delete Instructions to Tenderers – Part II Contained in the Edition of the Publication “Master Municipal Construction Documents 2009” and replace with the following:

**5.0 Tender  
Requirements**

- 5.1 A tender should be on the Form of Tender as provided and be signed by the authorized signatory(s) as follows:
- 5.1.1 if the tenderer is a partnership or joint venture then the name of the partnership or joint venturer should be included, and each partner or joint venturer should sign personally; if a partner of joint venture is a corporation then such corporation should sign as indicated in paragraph 5.1.3 below; and
  - 5.1.2 if the tenderer is a corporation then the full name of the corporation should be included, together with the names and signatures of authorized signatories.
  - 5.1.3 For the purpose of the Tender submission, digital copies of original documents and electronic signatures are accepted. Original documents are required upon request by the City.
- 5.2 A tender must be accompanied by tender security (“*Bid Security*”) in the form of:
- 5.2.1 a copy (digital or Electronic copy is acceptable) of the original bid bond in an amount equal to 10% of the Tender Price, issued by a surety licensed to carry on the business of suretyship in British Columbia in a form reasonably satisfactory to the *Owner*;
- 5.3 Tenderer should be competent and capable of performing the various items of work. Tenderer shall complete the following statement sheets appended to the Form of Tender:
- 5.3.1 Appendix 1 – the Schedule of Quantities and Prices;
  - 5.3.2 Appendix 2 – a “*Preliminary Construction Schedule*”, generally in the form attached as Appendix 2 to the Form of Tender, and showing *Substantial Performance* by the date or within the duration, shown in paragraph 2.2 of the Form of Tender.
  - 5.3.3 Appendix 3 – name and brief description of the previous experience of the *Superintendent* the tenderer will use for the *Work*;
  - 5.3.4 Appendix 4 – a list of previous comparable work, including a brief description of that work,

approximate contract value, and references (with phone numbers);

5.3.5 Appendix 5 – a complete list of all subcontractors, if any, that the tenderer will use for the *Work* including full names; and

5.3.6 Appendix 7 – is provided for information only, to indicate the Contract Insurance is to be submitted by the successful Tenderer upon Notice of Award.

5.4 The successful tenderer will, within 15 *Days* of receipt of the written *Notice of Award*, be required to deliver to the *Owner* the items listed in FT 5.1.1, including a Performance Bond and a Labour and Material Payment Bond as described in FT 5.1.1(a), failing which the provisions of FT 6.1 will apply.

**6.0 Qualifications, Modifications, Alternative Tenders**

6.1 Tenders which contain qualifications, or omissions, so as to make comparison which other tenders difficult, may be rejected by the *Owner*.

6.2 A tenderer may, at the tenderer's election, submit an alternative tender ("*Alternative Tender*") which varies the materials, products, designs or equipment by the *Owner as Approved Equals* as the case may be, but an *Alternative Tender* must be in addition to, and not in substitution for a tender which conforms to the requirements of the *Contract Documents*.

6.3 The only *Alternative Tender* that the *Owner* may accept is an *Alternative Tender* submitted by that tenderer whose conforming tender, submitted as required by paragraph 6.2 of these Instructions to Tenderers, would have been accepted by the *Owners* in the preference to other conforming tenders, if no *Alternative Tenders* had been invited.

**7.0 Approved Equals**

7.1 Prior to the *Tender Closing Time and Date*, a tenderer may request the *Owner* to approve materials, products, or equipment ("*Approved Equal*") to be included in a tender in substitution for items indicated in the Contract Documents.

7.2 Applications for an *Approved Equal* must be in writing, and supported by appropriate supporting information, data, specifications, and documentation.

7.3 If the *Owner* decides in its discretion to accept an *Approved Equal*, then the *Owner* will issue an addendum to all tenderers.

7.4 The *Owner* is not obligated to review or accept an application for an *Approved Equal*.

**8.0 Inspection of  
the Place of the  
Work**

- 8.1 All tenderers, either personally or through a representative, are responsible to examine the *Place of the Work* before submitting a tender. A tenderer has full responsibility to be familiar with and make allowance in the tender for all conditions at the *Place of the Work* that might affect the tender, including any information regarding subsurface soil conditions made available by the *Owner*, the location of the *Work*, local conditions, topographical soil conditions, weather and access. Unless otherwise specified in the *Contract Documents*, a tenderer is not required to do subsurface investigations. By submitting a tender, a tenderer represents that the tenderer has examined the *Place of the Work*, or specifically elected not to. No additional payments or time extensions shall be claimable or due because of difficulties relating to conditions at the *Place of the Work* which were reasonably foreseeable by a contractor qualified to undertake the *Work*.
- 8.2 Tenderers are referred to GC 11.2.1 regarding **Concealed or Unknown Conditions**.

**9.0 Interpretation  
of Contract  
Documents**

- 9.1 If a tenderer is in doubt as to the correct meaning of any provision of the *Contract Documents*, the tenderer may request clarification as instructed in paragraph 1.2 of the Instructions to Tenderers.
- 9.2 If a tenderer discovers any contradictions or inconsistencies in the *Contract Documents* or its provisions, or any discrepancies between a provision of the *Contract Documents* and conditions at the *Place of the Work as* observed in an examination under paragraph 8 of the person named in paragraph 1.2 of the Instructions to Tenderers.
- 9.3 If the *Owner* considers it necessary, the *Owner* may issue written addenda to provide clarification (s) of the *Contract Documents*.
- 9.4 No oral interpretation or representations from the *Owner* or any representative of the *Owner* will affect, alter, or amend any provision of the *Contract Documents*.

**10.0 Prices**

- 10.1 The Tendered Price will represent the entire cost excluding *GST* to the *Owner* of the complete *Work* based on the estimated quantities in the *Schedule of Quantities and Prices* of the Form of Tender. Notwithstanding the generalities of the above, tenderers shall include in the tendered prices (including unit prices, lump sum prices, or other forms of pricing) sufficient amounts to cover:
- 10.1.1 the costs of all labour, equipment and material included in or required for the *Work*, including all items which, whole not specifically listed in the *Schedule of Quantities and Prices*, are included in the *Work* specifically or by necessary inference from the *Contract Documents*;

10.1.2 all assessments payable with respect to labour as required by any statutory scheme such as unemployment insurance, holiday pay, insurance, CPP and all employee benefits and the Workers Compensation Act;

10.1.3 all overhead costs, including head office and on-site overhead costs, and all amounts for the *Contractor's* profit.

10.2 The tendered prices and all subcontracts must allow for compliance with all applicable laws regarding trade or other qualifications of employees performing the *Work*, and payment of appropriate wages for labour included in or required for the *Work*.

**11.0 Taxes**

11.1 The tendered prices shall cover all taxes and assessments of any kind payable with respect to the *Work*, but shall not include *GST*. *GST* shall be listed as a separate line item as required by GC 19.3.

**12.0 Amendment of Tenders**

12.1 A tenderer may amend or revoke a tender by giving written notice, delivered by Email, to the office referred to in paragraph 3.4 of the Instructions to Tenderers at any time up until the *Tender Closing Date and Time*. An amendment or revocation that is received after the *Tender Closing Date and Time* shall not be considered and shall not affect a tender as submitted.

12.2 An amendment or revocation must be signed by an authorized signatory of the tenderer in the same manner as provided by paragraph 5.1 of these Instructions to Tenderers.

12.3 Any amendment that expressly or by inference discloses the tenderer's *Tender Price* or other material element of the tender such that, in the opinion of the *Owner*, the confidentiality of the tender is breached, will invalidate the entire tender.

12.4 An acceptable form of a tender amendment which tenderers may, but are not required to, use is as follows:

"Contract: \_\_\_\_\_  
(TITLE OF CONTRACT)  
Reference No. \_\_\_\_\_  
(OWNER'S CONTRACT REFERENCE NO.)  
TO: \_\_\_\_\_  
(NAME OF OWNER)

We the undersigned wish to amend our tender which we submitted for the above *Contract* by deleting the following tendered prices or items from our tender:

---

---

(TENDERED PRICES AND/OR TENDER ITEMS IN THE TENDER THAT ARE TO BE AMENDED)

and substituting the following revised tendered prices or items:

---

---

(REVISED TENDERED PRICES OR TENDER ITEMS)

The extensions in our tender should be adjusted accordingly, and our **Tender Price** as set out in Appendix 1 of our submitted **Form of Tender**, and on the **Schedule of Quantities and Prices**, increased / decreased by \$\_\_\_\_\_, excluding GST. We have not included our revised **Tender Price** in order to preserve the confidentiality of our tender.

Signed and delivered the \_\_\_ day of \_\_\_\_\_, 20\_\_."

**13.0 Duration of Tenders**

13.1 After the *Tender Closing Time*, a tender shall remain valid and irrevocable as set out in paragraph 5.1 of the Form of Tender.

**14.0 Qualifications of Tenderers**

14.1 By submitting a tender, a tenderer is representing that it has the competence, qualifications and relevant experience required to do the *Work*.

**15.0 Award**

15.1 In exercising its discretion, the *Owner* will have regard to the information provided in the Appendices to the Form of Tender as described under IT 5.3 including the proven experience of the tenderer, and any listed subcontractors, to do the *Work*.

Tenders received will be evaluated to provide the City with greatest value based on quality, service, price and experience. Evaluation Criteria will include but is not limited to:

1. Ability to meet specifications and required completion date
2. Contractor's past experience, references, reputation and compliance to specifications
3. Demonstrated successful experience on similar projects and specific equipment installation
4. Price: purchase price, maintenance costs, availability of parts and service, warranty and compatibility with existing equipment and/or conditions

5. Any other criteria, the City deems, at its sole discretion, necessary to evaluate Tenders;
6. Lowest price will not necessarily be accepted.

The City may, in its absolute discretion, not award to a Tenderer if the Tenderer, or any officer or director of a corporate Tenderer, is or has been engaged, either directly or indirectly through another corporation or legal entity, in a legal action against the City and its elected and appointed officers and employees or any of them in relation to:

- a) any other contract or services; or
- b) any matter arising from the City's exercise of its powers, duties or functions under the *Local Government Act*, the *Community Charter* or any other enactments; within five years of this Tender Offer.

For purposes of this section, the words "legal action" includes, without limitation, mediation, arbitration, hearing before an administrative tribunal or lawsuit filed in any court.

Without limiting the City's sole discretion, in determining whether or not to award to a Tenderer pursuant to this clause, the City will consider such factors as whether the legal action is likely to affect the Tenderer's ability to work with the City and its employees, agents, consultants and representatives or any of them and whether the City's past experience with the Tenderer in the matter that resulted in the legal action indicates that the City is likely to incur increased staff and legal costs or either of them in the administration of this contract if it is awarded to the Tenderer.

In the event that the lowest total Tender Price by two or more Tenderers is the same amount, the City will select a Tenderer with an overall satisfactory performance record in having completed work on previous relevant projects that are provided as references, and on City projects. Information obtained from references will not be disclosed or discussed with any Tenderer. If all references are equal, selection will be determined by a coin toss in a manner to be directed by the City.

Where only one Tender is received the City may reject such and re-tender on a selected basis.

- 15.2 The *Owner* will notify the successful tenderer in writing.
- 15.3 If there are any discrepancies in the *Schedule of Quantities and Prices* between the unit prices and the extended totals then the unit prices shall be deemed correct, and corresponding corrections shall be made to the extended totals. If a unit price or extended total has been omitted, the following shall apply:

- a) If a unit price is given but the corresponding extended total has been omitted, then the extended total shall be calculated from unit price and the estimated quantity, and inserted as the extended total;
- b) If an extended total is given but the corresponding unit price has been omitted, then the unit price shall be calculated from the extended total and estimated quantity, and inserted as the unit price;
- c) If both the unit price and the corresponding extended total for a tender item have been omitted, then the following test shall be applied to determine whether the tender shall be rejected as incomplete:
  - (i) the highest of the unit prices tendered by other tenderers for that tender item shall be used as the test unit price, and the corresponding test extended total shall be calculated from the test unit price and the estimated quantity;
  - (ii) if the test extended total for the tender item exceeds 1% of the revised total *Tender Price*, including the test extended total, or if the revised total *Tender Price*, including the test extended total, alters the ranking of the tenderers according to the lowest *Tender Price*, then the omitted unit price for that tender item is deemed to materially affect the *Tender Price* relative to other tenders and the tender shall be rejected;
  - (iii) if the tender is not rejected under subparagraph (ii) of this IT 15.3 (c), then the unit price and the extended total for that tender item shall both be deemed to be, and the costs for that tender item shall be zero deemed to be included in other tender items prices;
- d) In no event shall page totals in the *Schedule of Quantities and Prices* or the total *Tender Price* be used to calculate missing extended totals or unit prices.

**16.0 Subcontractors**

- 16.1 The *Owner* reserves the right to object to any of the subcontractors listed in a tender. If the *Owner* objects to any of the subcontractor(s) then the *Owner* will permit a tenderer to, within 5 days, propose a substitute subcontractor(s) acceptable to the *Owner* provided that there is not resulting adjustment in the *Tender Price* or the completion date set out in paragraph 2.2 of the Form of Tender. A tenderer will not be required to make such substitution and, if the *Owner* objects to a listed *Subcontractor(s)*, the tenderer

may, rather than propose a substitute subcontractor(s), consider its tender rejected by the *Owner* and by written notice withdraw its tender. The *Owner* shall, in the event, return the tenderer's bid security.

**17.0 Optional Work**

17.1 If the *Schedule of Quantities and Prices* includes any tender prices for *Optional or Provisional Work*, as defined in GC 7.4.1, the tenderers must complete all the unit prices for such *Optional or Provisional Work*. Such tender prices shall not include any general overhead costs, or other costs, or profit, not directly related to the *Optional or Provisional Work*.

17.2 Notwithstanding that the *Owner* may elect not to proceed with the *Optional or Provisional Work*, the tender prices for any *Optional or Provisional Work*, including the extended totals for *Optional or Provisional Work* unit prices, shall be included in the *Tender Price* for the purpose of any price comparisons between tenders.

# ***Form of Tender***



## Form of Tender

Tender No. 79058

### Clarke & Glenayre and Lougheed & Woolridge Intersection Improvements

#### Summary

Name of **Contractor**: \_\_\_\_\_

**Tender Price** (exclude GST): \$ \_\_\_\_\_  
(FROM APPENDIX 1 OF FORM OF TENDER)

**Tender submitted must be accompanied by a copy of the original 10% Bid Bond and will be received**

**On or before 2:00 pm (local time)  
Thursday, June 4, 2026**

#### Instructions for Tender Submission

**Tender submissions are to be consolidated into one (1) .pdf file and uploaded electronically through QFile, the City's file transfer service accessed at website:**  
<https://qfile.coquitlam.ca/filedrop/purchasing>

- 1. In the "From" field enter:** Tenderers email address
- 2. In the "Subject" field enter:** Tender Name
- 3. In the "BID Number" field enter:** Tender Number
- 4. In the "Type" field enter:** **New** if this is a new submission or **Update** if this is an updated submission
- 5. Add consolidated Tender files in Adobe PDF format, and Appendix 1 in Microsoft Excel XLS format, and Send** (ensure your web browser remains open until you receive a files sent message. You will also receive an email from QFile confirming the submission)

**Tenderers are responsible to allow ample time to complete the Tender submission process. If assistance is required, phone 604-927-3037.**

May 2026

The City of Coquitlam  
3000 Guildford Way  
Coquitlam, B.C. V3B 7N2

---

( FOR USE WHEN UNIT PRICES FORM THE BASIS OF PAYMENT - TO BE USED ONLY WITH THE GENERAL CONDITIONS AND OTHER STANDARD DOCUMENTS OF THE UNIT PRICE MASTER MUNICIPAL CONSTRUCTION DOCUMENTS. )

**Contract Name: Clarke & Glenayre and Lougheed & Woolridge Intersection Improvements**  
**Reference No.: 79058**

**TO OWNER:**

**1 WE, THE UNDERSIGNED:**

1.1 have received and carefully reviewed all of the *Contract Documents*, including the Instructions to Tenderers, the City of Coquitlam Supplementary General Conditions, the City of Coquitlam Supplementary Contract Specifications, the specified edition of the "Master Municipal Construction Documents – General Conditions, Specifications and Standard Detail Drawings" and the following Addenda:

\_\_\_\_\_  
\_\_\_\_\_  
\_\_\_\_\_;

( ADDENDA, IF ANY )

1.2 shall fully disclose any actual or potential conflicts of interest and existing business relationships we may have with the City, their elected or appointed officials or employees:

\_\_\_\_\_

1.3 have full knowledge of the *Place of the Work*, and the *Work* required; and

1.4 have complied with the Instructions to Tenderers; and

**2 ACCORDINGLY WE HEREBY OFFER:**

2.1 to perform and complete all of the *Work* and to provide all the labour, equipment and material all as set out in the *Contract Documents*, in strict compliance with the *Contract Documents*; and

2.2 to achieve *Substantial Performance* of the *Work* on or before **September 15, 2026**; and

2.3 to do the *Work* for the price, which is the sum of the products of the actual quantities incorporated into the *Work* and the appropriate unit prices set out in Appendix 1, the "*Schedule of Quantities and Prices*", plus any lump sums or specific prices and adjustment amounts as provided by the *Contract Documents*. For the purposes of tender comparison, our offer is to complete the *Work* for the "*Tender Price*" as set out on Appendix 1 of this Form of Tender. Our *Tender Price* is based on the estimated quantities listed in the *Schedule of Quantities and Prices*, and excludes *GST*.

**3 WE CONFIRM:**

- 3.1 that we understand and agree that the quantities as listed in the *Schedule of Quantities and Prices* are estimated, and that the actual quantities will vary.
- 3.2 that we understand and agree that the owner is in no way obliged to accept this Tender.

**4 WE CONFIRM:**

- 4.1 that the following Appendices are attached to and form a part of this tender:
  - 4.1.1 the Appendices as required by paragraph 5.3 of the Instructions to Tenderers - Part II; and
  - 4.1.2 the *Bid Security* as required by paragraph 5.2 of the Instructions to Tenderers - Part II.
  - 4.1.3 the Certificate of Compliance on the form provided in Appendix 7 of this Form of Tender.

**5 WE AGREE:**

- 5.1 that this tender will be irrevocable and open for acceptance by the *Owner* for a period of **60** calendar days from the day following the *Tender Closing Date and Time*, even if the tender of another Tenderer is accepted by the *Owner*. If within this period the *Owner* delivers a written notice ("*Notice of Award*") by which the *Owner* accepts our tender we will:
  - 5.1.1 within **15 Days** of receipt of the written *Notice of Award* deliver to the *Owner*:
    - a) a Performance Bond and a Labour and Material Payment Bond, each in the amount of 50% of the *Contract Price*, issued by a surety licensed to carry on the business of suretyship in the province of British Columbia, and in a form acceptable to the *Owner*;
    - b) a "clearance letter" indicating that the Tenderer is in WCB compliance; and
    - c) a copy of the insurance policies as specified in SGC Section 24 indicating that all such insurance coverage is in place and;
    - d) a letter confirming the *Contractor* as "Prime Contractor" for the Contract as specified in SGC Section 21.2.1.
  - 5.1.2 within **2 Days** of receipt of written "*Notice to Proceed*", or such longer time as may be otherwise specified in the *Notice to Proceed*, commence the *Work*; and
  - 5.1.3 sign the Contract Documents as required by GC 2.1.

**6 WE AGREE:**

6.1 that, if we receive written *Notice of Award* of this *Contract* and, contrary to paragraph 5 of this Form of Tender, we:

6.1.1 fail or refuse to deliver the documents as specified by paragraph 5.1.1 of this Form of Tender; or

6.1.2 fail or refuse to commence the *Work* as required by the *Notice to Proceed*,

**then such failure or refusal will be deemed to be a refusal by us to enter into the *Contract*** and the *Owner* may, on written notice to us, award the *Contract* to another party. We further agree that, as full compensation on account of damages suffered by the *Owner* because of such failure or refusal, the *Bid Security* shall be forfeited to the *Owner*, in an amount equal to the lesser of:

6.1.3 the face value of the *Bid Security*; and

6.1.4 the amount by which our *Tender Price* is less than the amount for which the *Owner* contracts with another party to perform the *Work*.

**7 OUR ADDRESS** is as follows:

---

---

---

Phone: \_\_\_\_\_ - \_\_\_\_\_ - \_\_\_\_\_

Email: \_\_\_\_\_

Attention: \_\_\_\_\_

This Tender is executed this \_\_\_\_\_ day of \_\_\_\_\_, 20\_\_\_\_.

*Contractor:*

\_\_\_\_\_  
**(FULL LEGAL NAME OF CORPORATION, PARTNERSHIP OR INDIVIDUAL)**

\_\_\_\_\_  
**(AUTHORIZED SIGNATORY)**

\_\_\_\_\_  
**(AUTHORIZED SIGNATORY)**

**8 WE CONFIRM:**

8.1 our Goods and Services Tax (GST) registration status is as follows:

8.1.1 for information purposes, our GST Registration Number is:

\_\_\_\_\_  
**(GST REGISTRATION NUMBER)**

**or;**

8.1.2 by signature hereunder, we certify we are **not required** to provide a registration number:

\_\_\_\_\_  
**(AUTHORIZED SIGNATORY)**

\_\_\_\_\_  
**(AUTHORIZED SIGNATORY)**

**APPENDIX 1  
FORM OF TENDER**

**Contract 79058**

**Clarke & Glenayre and Loughed & Woolridge Intersection Improvements**

**SCHEDULE OF QUANTITIES AND PRICES**

(see paragraph 5.3.1 of the Instruction to Tenderers)

**(All Tender and Contract Prices shall NOT include GST. GST will apply upon payment)**

**(Should there be any discrepancy in the information provided, the City's original file copy shall prevail)**

ITEM NO.	MMCD Ref. / (Supp. Specs)	DESCRIPTION	UNIT	QTY	UNIT PRICE	EXTENDED AMOUNT
<b>SECTION 1 - Loughed Highway and Woolridge Connector</b>						
<b>1.00</b>	<b>01 58 015</b>	<b>PROJECT IDENTIFICATION</b>				
1.01	(1.3.1)	1.2m x 1.2m Static Construction Zone Information Sign	ea.	2		
1.02	(1.3.2)	Changeable Message Board Signs (Qty 2 )	month	1		
<b>2.00</b>	<b>03 30 205</b>	<b>CONCRETE WALKS, CURBS AND GUTTERS</b>				
2.01	(1.4.3)	Concrete Barrier Curb & Gutter (MMCD C5)	lin.m	45		
2.02	(1.4.3)	Interim Curb (COQ C6)	lin.m	34		
2.03	(1.4.5)	Concrete Sidewalk, Ramps AND Bus Passenger Landing Pad - 100mm Thick	sq.m	76		
2.04	(1.4.5)	Concrete Median infill - 100mm Thick	sq,m	27		
2.05	(1.4.10)	Tactile Strip - 24x24in - Access Tile, Yellow color - removable type	sq.m	13		
<b>3.00</b>	<b>31 11 015</b>	<b>CLEARING AND GRUBBING</b>				
3.01	(1.4.1)	Clearing & grubbing	l.s	1		
<b>4.00</b>	<b>32 11 16.15</b>	<b>GRANULAR SUBBASE</b>				
4.01	(1.4.3)	75mm Select Granular SubBase (SGSB) (Variable thickness)	tonnes	8		
<b>5.00</b>	<b>32 11 235</b>	<b>GRANULAR BASE</b>				
5.01	(1.4.3)	25mm Minus Granular Base\ (Variable thickness)	tonnes	46		
<b>6.00</b>	<b>31 24 135</b>	<b>ROADWAY EXCAVATION, EMBANKMENT AND COMPACTION</b>				
6.01	(1.8.5)	Common Excavation - Off-Site Disposal (Provisional)	cu.m	15		
6.02	(1.8.4)	Removal and Disposal of Existing Concrete Curbs	lin.m	45		
6.03	(1.8.4)	Removal and Disposal of Existing Concrete Median and Sidewalk	sq.m	80		
6.04	(1.8.4)	Removal and Disposal of Existing Asphalt	sq.m	28		
6.05	(1.8.10)	Overexcavation, Offsite Disposal, Backfilling (Provisional)	cu.m	5		
<b>7.00</b>	<b>32 12 165</b>	<b>HOT-MIX ASPHALT CONCRETE PAVING</b>				
7.01	(1.5.3)	Asphalt Pavement - Lower Course #1 (Slot Paving <1.0m Wide)	tonnes	4		
7.02	(1.5.3)	Asphalt Pavement - Upper Course #1 (Slot Paving <1.0m Wide)	tonnes	4		
<b>8.00</b>	<b>32 17 235</b>	<b>PAINTED PAVEMENT MARKINGS</b>				
8.01	(1.5.3)	Supply and Installation of Thermoplastic Pavement Markings	l.s	1		
8.02	(1.5.4)	Relocate Existing Signage	ea.	4		
<b>9.00</b>	<b>32 31 135</b>	<b>CHAIN LINK FENCES AND GATES</b>				
9.01	(1.5.4)	Handrail (1.2m High) at Crosswalk (MMCD C14 Powder Coated Black)	lin.m	32		

**SCHEDULE OF QUANTITIES AND PRICES**

(see paragraph 5.3.1 of the Instruction to Tenderers)

(All Tender and Contract Prices shall NOT include GST. GST will apply upon payment)

(Should there be any discrepancy in the information provided, the City's original file copy shall prevail)

ITEM NO.	MMCD Ref. / (Supp. Specs)	DESCRIPTION	UNIT	QTY	UNIT PRICE	EXTENDED AMOUNT
<b>10.00</b>	<b>32 84 235</b>	<b>IRRIGATION</b>				
10.01	(1.11)	Removal of irrigation heads, adjustments to irrigation line, cut and capping as required; including irrigation sleeving. All work to be done by a certified irrigation contractor.	l.s	1		
<b>11.00</b>	<b>33 40 015</b>	<b>STORM SEWER</b>				
11.01	(1.6.5)	Lawn Drain Lead (PVC SDR28, 150mm Dia., All Depths, Imported Backfill; including removal and disposal of existing perforated pipe.	lin.m	8		
<b>12.00</b>	<b>33 44 01</b>	<b>MANHOLES &amp; CATCHBASINS</b>				
12.01	(1.5.2)	Reinstatement of Curb Side Inlet	ea.	1		
12.02	(1.5.2)	Lawn Drain (concrete, 600mm dia., all depths (MMCD S12)	ea.	1		
<b>13.00</b>	<b>34 41 135</b>	<b>TRAFFIC SIGNALS</b>				
13.01	1.9.2	Supply & Installation of Traffic Signals, junction boxes, and required ducting. All Works, Including any removal, adjustments and disposal needed to complete the work and as shown on the Contract Drawings	l.s	1		
<b>TOTAL FOR SECTION 1</b>						
<b>SECTION 2 - Clarke Road and Glenayre Traffic Signal Improvements</b>						
<b>14.00</b>	<b>01 58 015</b>	<b>PROJECT IDENTIFICATION</b>				
14.01	(1.3.1)	1.2m x 1.2m Static Construction Zone Information Sign	Each	2		
14.02	(1.3.2)	Changeable Message Board Signs (Qty 2 )	Month	1		
<b>15.00</b>	<b>03 30 205</b>	<b>CONCRETE WALKS, CURBS AND GUTTERS</b>				
15.01	(1.4.3)	Concrete Barrier Curb & Gutter (MMCD C5)	lin.m	12		
15.02	(1.4.3)	Existing Median Curb Replacement (Match Existing)	lin.m	18		
15.03	(1.4.5)	Concrete Sidewalk, Ramps AND Bus Passenger Landing Pad - 100mm Thick	sq.m	50		
15.04	(1.4.5)	Concrete Median infill - 100mm Thick Match Existing	sq,m	22		
15.05	(1.4.5)	Concrete Driveway Crossings - COQ-C7	sq,m	23		
<b>16.00</b>	<b>31 11 015</b>	<b>CLEARING AND GRUBBING</b>				
16.01	(1.4.1)	Clearing & grubbing	l.s	1		
<b>17.00</b>	<b>31 24 135</b>	<b>ROADWAY EXCAVATION, EMBANKMENT AND COMPACTION</b>				
17.01	(1.8.4)	Removal and Disposal of Existing Concrete Curbs	lin.m	29		
17.02	(1.8.4)	Removal and Disposal of Existing Concrete Sidewalks, Driveway Crossings, and Median	sq.m	93		
17.03	(1.8.4)	Removal and Disposal of Existing Asphalt	sq.m	53		
17.04	(1.8.10)	Overexcavation, Offsite Disposal, Backfilling (Provisional)	cu.m	5		
<b>18.00</b>	<b>32 11 16.15</b>	<b>GRANULAR SUBBASE</b>				
18.01	(1.4.3)	75mm Select Granular SubBase (SGSB) (Variable thickness) (Provisional)	tonnes	8		
<b>19.00</b>	<b>32 11 235</b>	<b>GRANULAR BASE</b>				
19.01	(1.4.3)	25mm Minus Granular Base (Variable thickness)	tonnes	46		

**SCHEDULE OF QUANTITIES AND PRICES**

(see paragraph 5.3.1 of the Instruction to Tenderers)

**(All Tender and Contract Prices shall NOT include GST. GST will apply upon payment)**

**(Should there be any discrepancy in the information provided, the City's original file copy shall prevail)**

ITEM NO.	MMCD Ref. / (Supp. Specs)	DESCRIPTION	UNIT	QTY	UNIT PRICE	EXTENDED AMOUNT
<b>20.00</b>	<b>32 12 165</b>	<b>HOT-MIX ASPHALT CONCRETE PAVING</b>				
20.01	(1.5.1)	Asphalt Pavement Upper Course #1- Permanent Trench Repairs as per COQ G4; max of 75 mm per lift, minimum 50mm	tonnes	20		
<b>21.00</b>	<b>32 17 235</b>	<b>PAINTED PAVEMENT MARKINGS</b>				
21.01	(1.5.3)	Supply and Installation of Thermoplastic Pavement Markings	l.s	1		
<b>22.00</b>	<b>34 41 135</b>	<b>TRAFFIC SIGNALS</b>				
22.01	1.9.2	Supply & Installation of Traffic Signals, junction boxes, and required ducting. All Works, Including any removal, adjustments and disposal needed to complete the work and as shown on the Contract Drawings	l.s	1		
<b>TOTAL FOR SECTION 2</b>						

**Total Tendered Price - All Sections (exclude GST):** \_\_\_\_\_

(Transfer the amount to Form of Tender Summary Page 1)

**Name of Contractor:** \_\_\_\_\_

**APPENDIX 2**

**FORM OF TENDER**

**Contract 79058**

**Clarke & Glenayre and Lougheed & Woolridge Intersection Improvements**

**PRELIMINARY CONSTRUCTION SCHEDULE**

(See paragraph 5.3.2 of the Instructions to Tenderers)

INDICATE SCHEDULE WITH BAR CHART WITH CONSTRUCTION DURATIONS

CONSTRUCTION ACTIVITY	JULY				AUGUST				SEPTEMBER	
	1	2	3	4	1	2	3	4	1	2

Substantial Completion Date: **September 15, 2026**

Proposed Disposal Site: \_\_\_\_\_

**APPENDIX 3**

**FORM OF TENDER**

**Contract 79058**

**Clarke & Glenayre and Lougheed & Woolridge Intersection Improvements**

**EXPERIENCE OF SUPERINTENDENT**

(See paragraph 5.3.3 of the Instructions to Tenderers)

Proposed Project Superintendent \_\_\_\_\_

**List of Project Experience**

<b>PROJECT:</b>		<b>Dates:</b>	
<b>Work Description:</b>			
<b>Responsibility:</b>			
<b>Owner/Reference:</b>		<b>Phone No.:</b>	

<b>PROJECT:</b>		<b>Dates:</b>	
<b>Work Description:</b>			
<b>Responsibility:</b>			
<b>Owner/Reference:</b>		<b>Phone No.:</b>	

<b>PROJECT:</b>		<b>Dates:</b>	
<b>Work Description:</b>			
<b>Responsibility:</b>			
<b>Owner/Reference:</b>		<b>Phone No.:</b>	

**APPENDIX 4**

**FORM OF TENDER**

**Contract 79058**

**Clarke & Glenayre and Lougheed & Woolridge Intersection Improvements**

**CONTRACTOR'S COMPARABLE WORK EXPERIENCE**

(See paragraph 5.3.4 of the Instructions to Tenderers)

<b>PROJECT:</b>		<b>VALUE (\$):</b>	
<b>OWNER:</b>		<b>Phone No.:</b>	
<b>Work Description:</b>			

<b>PROJECT:</b>		<b>VALUE (\$):</b>	
<b>OWNER:</b>		<b>Phone No.:</b>	
<b>Work Description:</b>			

<b>PROJECT:</b>		<b>VALUE (\$):</b>	
<b>OWNER:</b>		<b>Phone No.:</b>	
<b>Work Description:</b>			

<b>PROJECT:</b>		<b>VALUE (\$):</b>	
<b>OWNER:</b>		<b>Phone No.:</b>	
<b>Work Description:</b>			

**APPENDIX 5**

**FORM OF TENDER**

**Contract 79058**

**Clarke & Glenayre and Lougheed & Woolridge Intersection Improvements**

**SUBCONTRACTORS**

(See paragraph 5.3.5 of the Instructions to Tenderers)

<b>Trade:</b>		<b>Tender Item:</b>	
<b>Work Description:</b>			
<b>Subcontractor:</b>		<b>Phone No.:</b>	

<b>Trade:</b>		<b>Tender Item:</b>	
<b>Work Description:</b>			
<b>Subcontractor:</b>		<b>Phone No.:</b>	

<b>Trade:</b>		<b>Tender Item:</b>	
<b>Work Description:</b>			
<b>Subcontractor:</b>		<b>Phone No.:</b>	

<b>Trade:</b>		<b>Tender Item:</b>	
<b>Work Description:</b>			
<b>Subcontractor:</b>		<b>Phone No.:</b>	

<b>Trade:</b>		<b>Tender Item:</b>	
<b>Work Description:</b>			
<b>Subcontractor:</b>		<b>Phone No.:</b>	

**APPENDIX 6**  
**FORM OF TENDER**  
**Contract 79058**  
**Clarke & Glenayre and Lougheed & Woolridge Intersection Improvements**  
**Bid Bond**

NO. \_\_\_\_\_

\$ \_\_\_\_\_

KNOW ALL MEN BY THESE PRESENTS THAT

\_\_\_\_\_

As Principal, hereinafter called the Principal, and

\_\_\_\_\_

As Surety, hereinafter called the Surety, are held and firmly bound unto

\_\_\_\_\_

As Obligee, hereinafter called the Obligee, in the amount of

\_\_\_\_\_ Dollars (\$\_\_\_\_\_) lawful money of  
 Canada, for the payment of which sum, well and truly to be made, the Principal and the Surety bind  
 themselves, their heirs, executors, administrators, successors and assigns, jointly and severally, firmly by these  
 presents.

WHEREAS, the Principal has submitted a written Tender to the Obligee, dated the \_\_\_\_\_ day of  
 \_\_\_\_\_, 2026, for Contract \_\_\_\_\_.

NOW, THEREFORE, THE CONDITION OF THIS OBLIGATION is such that if the aforesaid Principal shall have the  
 Tender accepted within sixty (60) days from the Closing Date of Tender and the said Principal will, within the  
 time required, enter into a formal contract and give good and sufficient bonds to secure the performance of  
 the terms and conditions of the Contract, then this obligation shall be null and void; otherwise the Principal  
 and Surety will pay unto the Obligee the difference in money between the amount of the bid of the said  
 Principal and the amount for which the Obligee legally contracts with another party to perform the work if the  
 latter amount be in excess of the former.

The Surety shall not be liable for a greater sum than the specified penalty of this Bond.

Any suit under this Bond must be instituted before the expiration of six (6) months from the date of this Bond.

IN TESTIMONY WHEREOF, the Principal has hereto set its hand and affixed its seal, and the Surety has caused  
 these presents to be sealed with its corporate seal duly attested by the signature of its Attorney-In-Fact,  
 this \_\_\_\_\_ day of \_\_\_\_\_, 2026.

SIGNED, SEALED AND DELIVERED  
 In the presence of:

_____ )	
) )	_____ )
) )	PRINCIPAL
) )	_____ )
_____ )	SURETY

---

**APPENDIX 7**

**FORM OF TENDER**

**Contract 79058**

**Clarke & Glenayre and Lougheed & Woolridge Intersection Improvements**

**CERTIFICATE OF COMPLIANCE for CONTRACT INSURANCE**

---

This is provided for information to certify that the Tenderer does hereby undertake and agree to supply to the City of Coquitlam, upon award, contract insurance listed below for the project requirements indicated:

**Contract Number:** 79058  
**Contract Name:** Clarke & Glenayre and Lougheed & Woolridge Intersection Improvements

**Description of Work:**

- Clarke Rd & Glenayre Drive  
Conversion of protected left turn signal phasing to protected only; safety improvement to address deficient vertical sight lines of South Bound vehicles
- Lougheed Hwy & Woolridge Connector  
Conversion of left turn half signal to two-stage pedestrian signal; provide safe highway crossing for pedestrians and bikes; Concrete works
- Other Miscellaneous Works as required

**Commercial General Liability:** \$5,000,000 limit

**Special Coverage Required:**

<u>YES</u>	<u>NO</u>	<u>Special Coverage Description</u>
( )	( X )	Shoring and Underpinning Hazard
( )	( X )	Pile Driving and Vibrations
( )	( X )	Excavation Hazard
( )	( X )	Demolition
( )	( X )	Blasting

We also certify that the insurance coverage will meet the requirements of the Supplementary General Conditions Section 24 - Insurance, included as part of the Contract Documents, and that the proof of insurance will be provided on the City of Coquitlam Certificate of Insurance form, without amendments, except for the exclusions noted above.

---

Name of Tenderer (printed)

---

Authorized Signature

---

Date

# ***Agreement***

---

## AGREEMENT

### Between Owner and Contractor

( FOR USE WHEN UNIT PRICES FORM THE BASIS OF PAYMENT - TO BE USED ONLY WITH THE GENERAL CONDITIONS AND OTHER STANDARD DOCUMENTS OF THE UNIT PRICE MASTER MUNICIPAL CONSTRUCTION DOCUMENTS. )

**THIS AGREEMENT** made in duplicate this \_\_\_\_ day of \_\_\_\_\_ 2026.

**Contract:** Clarke & Glenayre and Lougheed & Woolridge Intersection Improvements

**Reference No.** 79058

**BETWEEN:**

The City of Coquitlam  
3000 Guildford Way  
Coquitlam, B.C. V3B 7N2

(the "Owner")

**AND:**

(the "Contractor")

The *Owner* and the *Contractor* agree as follows:

**1 THE WORK - START/COMPLETION DATES**

- 1.1 The *Contractor* will perform all *Work* and provide all labour, equipment and material and do all things strictly as required by the *Contract Documents*.
- 1.2 The *Contractor* will commence the *Work* in accordance with the *Notice to Proceed*. The *Contractor* will proceed with the *Work* diligently, will perform the *Work* generally in accordance with the construction schedules as required by the *Contract Documents* and will achieve *Substantial Performance* of the *Work* on or before **September 15, 2026**, subject to the provisions of the *Contract Documents* for adjustments to the *Contract Time*.
- 1.3 Time shall be the essence of the Contract.

## **2 CONTRACT DOCUMENTS**

- 2.1 The "*Contract Documents*" consist of the documents listed or referred to in Schedule 1, entitled "*Schedule of Contract Documents*", which is attached and forms a part of this Agreement, and includes any and all additional and amending documents issued in accordance with the provisions of the *Contract Documents*. All of the *Contract Documents* shall constitute the entire *Contract* between the *Owner* and the *Contractor*.
- 2.2 The *Contract* supersedes all prior negotiations, representations or agreements, whether written or oral, and the *Contract* may be amended only in strict accordance with the provisions of the *Contract Documents*.

## **3 CONTRACT PRICE**

- 3.1 The price for the *Work* ("*Contract Price*") shall be the sum in Canadian dollars of the following:
- a) the product of the actual quantities of the items of *Work* listed in the *Schedule of Quantities and Prices* which are incorporated into or made necessary by the *Work* and the unit prices listed in the *Schedule of Quantities and Prices*; plus
  - b) all lump sums, if any, as listed in the *Schedule of Quantities and Prices*, for items relating to or incorporated into the *Work*; plus
  - c) any adjustments, including any payments owing on account of *Changes* and agreed to *Extra Work*, approved in accordance with the provisions of the *Contract Documents*.
- 3.2 The *Contract Price* shall be the entire compensation owing to the *Contractor* for the *Work* and this compensation shall cover and include all profit and all costs of supervision, labour, material, equipment, overhead, financing, and all other costs and expenses whatsoever incurred in performing the *Work*.

## **4 PAYMENT**

- 4.1 Subject to applicable legislation and the provisions of the *Contract Documents*, the *Owner* shall make payments to the *Contractor*.
- 4.2 If the *Owner* fails to make payments to the *Contractor* as they become due in accordance with the terms of the *Contract Documents* then interest calculated at 2% per annum over the prime commercial lending rate of the Royal Bank of Canada on such unpaid amounts shall also become due and payable until payment. Such interest shall be calculated and added to any unpaid amounts monthly.

## **5 RIGHTS AND REMEDIES**

- 5.1 The duties and obligations imposed by the *Contract Documents* and the rights and remedies available hereunder shall be in addition to and not a limitation of any duties, obligations, rights and remedies otherwise imposed or available by law.

5.2 Except as specifically set out in the *Contract Documents*, no action or failure to act by the *Owner*, *Contract Administrator* or *Contractor* shall constitute a waiver of any of the parties' rights or duties afforded under the *Contract*, nor shall any such action or failure to act constitute an approval of or acquiescence in any breach under the *Contract*.

## 6 NOTICES

6.1 Communications among the *Owner*, the *Contract Administrator* and the *Contractor*, including all written notices required by the *Contract Documents*, may be delivered by email, or by hand, or by pre-paid registered mail to the addresses as set out below:

The *Owner*:

The City of Coquitlam  
3000 Guildford Way  
Coquitlam, B.C. V3B 7N2

Tel: 604-927-3500

The *Contractor*:

Tel:  
Email:  
Attention:

The *Contract Administrator*:

The City of Coquitlam  
3000 Guildford Way  
Coquitlam, B.C. V3B 7N2

Tel:  
Email:  
Attention:

6.2 A communication or notice that is addressed as above shall be considered to have been received:

- a) immediately upon delivery, if delivered by hand; or
- b) immediately upon transmission if sent or received by email; or
- c) after 5 days from date of posting if sent by registered mail.

6.3 The *Owner* or the *Contractor* may, at any time, change its address for notice by giving written notice to the other at the address then applicable. Similarly if the *Contract Administrator* changes its address for notice then the *Owner* will give or cause to be given written notice to the *Contractor*.

## 7 GENERAL

7.1 This *Contract* shall be construed according to the laws of British Columbia.

- 7.2 The *Contractor* shall not, without the express written consent of the *Owner*, assign this *Contract*, or any portion of this *Contract*.
- 7.3 The headings included in the *Contract Documents* are for convenience only and do not form part of this *Contract* and will not be used to interpret, define or limit the scope or intent of this *Contract* or any of the provisions of the *Contract Documents*.
- 7.4 A word in the *Contract Documents* in the singular includes the plural and, in each case, vice versa.
- 7.5 This agreement shall enure to the benefit of and be binding upon the parties and their successors, executors, administrators and assigns

IN WITNESS WHEREOF the parties hereto have executed this Agreement the day and year first written above.

*Contractor:*

\_\_\_\_\_  
(FULL LEGAL NAME OF CORPORATION, PARTNERSHIP OR INDIVIDUAL)

\_\_\_\_\_  
(AUTHORIZED SIGNATORY)

\_\_\_\_\_  
(AUTHORIZED SIGNATORY AND POSITION - PRINT)

*Owner:*

The City of Coquitlam

\_\_\_\_\_  
**Edwin Dela Rosa, ASCT**  
(MANAGER, CAPITAL PROJECTS AND INSPECTIONS)  
Representative as Per G.C. 17

\_\_\_\_\_  
**Chad Braley, ASCT**  
(SENIOR MANAGER, DESIGN AND CONSTRUCTION)

---

**Clarke & Glenayre and Lougheed & Woolridge Intersection Improvements**

**Reference No: 79058**

**Schedule 1**

**Schedule of Contract Documents**

**(INCLUDE IN LIST ALL DOCUMENTS INCLUDING, IF ANY, SUPPLEMENTARY GENERAL CONDITIONS, SUPPLEMENTARY SPECIFICATIONS, SUPPLEMENTARY STANDARD DETAIL DRAWINGS)**

The following is an exact and complete list of the *Contract Documents*, as referred to in Article 2.1 of the Agreement.

**NOTE:** The documents noted with "\*" are contained in the "Master Municipal Construction Documents – General Conditions, Specifications and Standard Detail Drawings", edition dated 2009. All sections of this publication are included in the *Contract Documents*.

1. Agreement, including all Schedules;
2. The following Addenda:
  - As issued
3. Supplementary General Conditions, if any;
4. General Conditions\*;
5. Supplementary Specifications, if any;
6. Detail Specifications, if any;
7. Specifications\*;
8. Supplementary Detail Drawings, if any;
9. Standard Detail Drawings\*;
10. Executed Form of Tender, including all Appendices;
11. Drawings listed in Schedule 2 to the Agreement – "List of Drawings", if any;
12. Instructions to Tenderers;
13. COQUITLAM "Supplementary Specifications Master Municipal Construction Documents" March 2022

**Clarke & Glenayre and Lougheed & Woolridge Intersection Improvements**

Reference No: 79058

**Schedule 2**

**LIST OF DRAWINGS**

**(Complete Listing of All Drawings, Plans and Sketches That Are Part of the Contract Documents)**

**Bound in this Document:**

**Appendix A: Traffic Management Detail Specifications**

**Appendix B: Archaeological Chance Find Procedures**

**Appendix C: As-built Records**

**Appendix D: Standard Detail Drawings**

**Appendix E: Irrigation As-built Record Drawings**

**Bound Separately: Contract Drawings**

TITLE	SHEET NO.	REVISION NO.	DATE
COVER	00 of 05	-	-
GENERAL NOTES	01 of 05	3	2026-05-13
KEY PLAN - LOUGHEED-WOOLRIDGE	02 of 05	4	2026-05-13
KEY PLAN - CLARKE-GLENAYRE	03 of 05	2	2026-05-13
PAVEMENT MARKING AND SIGNAGE	04 of 05	3	2026-05-13
DETAILS	05 of 05	3	2026-05-13
TRAFFIC SIGNAL MODIFICATION - LOUGHEED HIGHWAY WOOLRIDGE CONNECTOR	01 of 02	-	2026-05-08
TRAFFIC SIGNAL MODIFICATION - LOUGHEED HIGHWAY WOOLRIDGE CONNECTOR	02 of 02	-	2026-05-08
TRAFFIC SIGNAL MODIFICATION - GLENAYRE DRIVE CLARKE ROAD	01 of 02	-	2026-05-08
TRAFFIC SIGNAL MODIFICATION - GLENAYRE DRIVE CLARKE ROAD	02 of 02	-	2026-05-08

# ***Supplementary General Conditions***

## SUPPLEMENTARY GENERAL CONDITIONS

### TABLE OF CONTENTS

	Page
Supplementary General Conditions to MMCD Volume II, 2009 Issue .....	SGC 1 to SGC 18
<b>Section 1: DEFINITIONS .....</b>	<b>SGC 3</b>
1.1 Abnormal Weather .....	SGC 3
<b>Section 2: DOCUMENTS .....</b>	<b>SGC 3</b>
2.2 Interpretation.....	SGC 3
<b>Section 4: CONTRACTOR .....</b>	<b>SGC 3 to 7</b>
4.1 Control of Work.....	SGC 3
4.2 Safety .....	SGC 4
4.3 Protection of Work, Property and the Public.....	SGC 4
4.6 Construction Schedule .....	SGC 5
4.7 Superintendent.....	SGC 5
4.8 Workers.....	SGC 5
4.9 Materials.....	SGC 6
4.11 Subcontractors.....	SGC 6
4.12 Tests and Inspections.....	SGC 6
4.14 Final Clean-up.....	SGC 7
4.16 Notice of Disruption .....	SGC 7
<b>Section 7: CHANGES.....</b>	<b>SGC 7 to 8</b>
7.1 Changes .....	SGC 7
7.4 Optional Work .....	SGC 7
<b>Section 9: VALUATION OF CHANGES AND EXTRA WORK .....</b>	<b>SGC 8</b>
9.2 Valuation Method .....	SGC 8
9.4 Quantity Variations.....	SGC 8
<b>Section 10: FORCE ACCOUNTS .....</b>	<b>SGC 8</b>
10.1 Force Account Costs .....	SGC 8
<b>Section 12: HAZARDOUS MATERIALS .....</b>	<b>SGC 9</b>
12.2 Discovery of Hazardous Materials .....	SGC 9
<b>Section 13: DELAYS .....</b>	<b>SGC 9 to 10</b>
13.1 Delay by Owner or Contract Administrator .....	SGC 9
13.3 Unavoidable Delay.....	SGC 9
13.8 Direction to Stop or Delay.....	SGC 9
13.9 Liquidated Damages for Late Completion.....	SGC 9
<b>Section 18: PAYMENT .....</b>	<b>SGC 10 to 11</b>
18.1 Preparation of Payment Certificate .....	SGC 10

18.4	Holdbacks .....	SGC 10
18.6	Substantial Performance .....	SGC 10
<b>Section 19: TAXES, DUTIES AND GST .....</b>		<b>SGC 11 to 12</b>
19.4	Tariffs or Duties .....	SGC 11
<b>Section 21: WORKERS COMPENSATION REGULATIONS .....</b>		<b>SGC 12</b>
21.2	Contractor is "Prime Contractor" .....	SGC 12
<b>Section 24: INSURANCE.....</b>		<b>SGC 12 to 17</b>
24.1	General .....	SGC 12
24.2	Required Insurance .....	SGC 13
24.3	Physical Loss or Damage with Respect to New Buildings under Construction and/or Major Additions to Existing Structures .....	SGC 14
24.4	Additional Insured .....	SGC 17
<b>Section 25: MAINTENANCE PERIOD .....</b>		<b>SGC 17</b>
25.1	Correction of Defects .....	SGC 17
<b>Section 27: CONTRACTOR PERFORMANCE EVALUATION .....</b>		<b>SGC 18</b>
<b>APPENDICES .....</b>		<b>SGC 19 to SGC 25</b>
<b>Appendix I</b>	Performance Bond .....	SGC 19 to 20
<b>Appendix II</b>	Labour and Material Payment Bond .....	SGC 21 to 23
<b>Appendix III</b>	Certificate of Insurance .....	SGC 24
<b>Appendix IV</b>	Prime Contractor Designation Letter .....	SGC 25

**1.0 DEFINITIONS**

- 1.1 Abnormal Weather** 1.1.1 **(Replace clause 1.1.1 as follows):**  
Abnormal Weather” means temperature, precipitation, wind or other weather conditions in which the monthly average, differs from the statistical average for that condition in that period by more than one standard deviation, calculated based on data available from Environment Canada. Coquitlam’s Burke Mountain Rain Gauge will be used to compare the rainfall summary versus the available data from Environment Canada.  
[City of Coquitlam Rainfall](#)

**2.0 DOCUMENTS**

- 2.2 Interpretation** 2.2.4 (1) **(Replace clause 2.2.4 (1) as follows):**  
The Contract Documents shall govern and take precedence in the following order as listed in Schedule 1 of the Agreement, taking precedence over all Contract Documents.

**4.0 CONTRACTOR**

- 4.1 Control of the Work** 4.1.1 **(Add to clause 4.1.1 as follows):**  
The *Contractor* is responsible for all survey layout for the construction of the Work to the design specifications and/or elevations as shown on the contract drawings or as amended on site by the Contract Administrator, unless otherwise described in the Contract Document.

- 4.1.2 **(Add to clause 4.1.2 as follows):**  
The Contractor shall not deposit any material upon any street, sidewalk, boulevard or other property, without the Contract Administrator’s or the Owner’s permission, nor shall they allow the same to remain longer than necessary. All surplus spoil and rubbish and other waste material shall be removed from the site so that the area of work is cleaned up and restored to as clean a condition as it was before the Contract started, within four days of the Contract Administrator’s written request to do so, failing which the Owner may carry out the work or have the work carried out by others and recover the costs from the Contractor or may deduct the cost from any monies due or that may become due to the Contractor.

- 4.1.3 **(Add new clause 4.1.3 as follows):**  
Work can be performed during the normal weekday working hours of 0700h to 1900h, unless specified otherwise in Supplementary Specifications - Appendix A:

These Supplementary General Conditions must be read in conjunction with the General Conditions contained in the Master Municipal Construction Documents, Volume II, Printed 2009

Traffic Management Detail Specifications. Written permission from the Contract Administrator will be required for any works to be performed outside of the normal working days of Monday to Friday.

No Sunday work will be permitted, except in case of emergency and then only with the written permission of the Contract Administrator and to such extent as he deems necessary.

In case the Contractor decides to work on a day which is a Statutory Holiday, they shall provide the Contract Administrator in writing at least (4) days in advance of such holiday, stating those places where said work is to be conducted. In case the Contractor fails to give such notice in advance of any Statutory Holiday, no work within the terms of the contract shall be done on such holiday.

**The cost of inspections on a Sunday or on a Statutory Holiday by City staff/s will be at Contractor's expense.**

**4.2 Safety**

4.2.2

***(Add new clause 4.2.2 as follows):***

*In an emergency, gas pipeline rupture or leak, Contact FortisBC's 24 Hour Emergency Line (1-800-663-9911) and Coquitlam Fire (911) immediately and then City of Coquitlam's Utility Control Centre (604-927-6287).*

**4.3 Protection of Work, Property and the Public**

4.3.1

***(Replace clause 4.3.1 as follows):***

In performing the Work, the Contractor shall protect the Work and the Owner's property and other person's property from damage. The Contractor shall at the Contractor's own expense make good any such damage which arises as the result of the Contractor's operations. If the Contractor causes damage to private property, the Contractor must obtain a written release from the owner of the damaged property.

4.3.5.1

***(Add clause 4.3.5.1 as follows):***

The Contractor shall notify the Contract Administrator immediately if damage occurs to any City or third party utility or structure.

4.3.7

***(Add new clause 4.3.7 as follows):***

Any lands other than those upon which the work is to be performed, which may be required for temporary facilities, storage purposes or access to the work site, other than those provided by the *Owner*, shall be provided by the *Contractor* at their own cost, with no liability to the *Owner*.

- |            |                              |       |   |
|------------|------------------------------|-------|---|
| <b>4.6</b> | <b>Construction Schedule</b> | 4.6.1 | <b><i>(Replace clause 4.6.1 as follows):</i></b><br>The Contractor shall within the time set out in the Form of Tender prepare and submit to the Contract Administrator for their approval a construction schedule (the Baseline Construction Schedule) indicating the planned start and completion dates of major activities of the Work. The Baseline Construction Schedule shall be in more detail than the Preliminary Construction Schedule and shall indicate completion of the Work in compliance with any specified Milestone Dates, including Substantial Performance. |
|            |                              | 4.6.6 | <b><i>(Replace clause 4.6.6 as follows):</i></b><br>The time for the performance of the Work shall commence on the date specified in the Notice to Proceed, or if not so specified, on the date the Notice to Proceed is issued. The Notice to Proceed will not be issued until the documentation required under paragraph 5.1.1 of the Form of Tender has been submitted and the construction schedule has been approved.  |
|            |                              | 4.6.8 | <b><i>(Add new clause 4.6.8 as follows):</i></b><br>Any requests to lengthen the work schedule shall be made in writing by the Contractor within five working days of knowledge of the reason for the extension. The Contract Administrator will adjust the schedule at their discretion upon receipt of a written request.   |
| <b>4.7</b> | <b>Superintendent</b>        | 4.7.4 | <b><i>(Add new clause 4.7.4 as follows):</i></b><br>The key personnel named in the Contractor's Tender response, shall remain in these key positions throughout the project. In the event that key personnel leave the Contractor's firm, or for any unknown reason are unable to continue fulfilling their role, the Contractor must propose a suitable replacement, and obtain written consent from the Owner. Acceptance of the proposed replacement is at the sole discretion of the Contract Administrator and the Owner.  |
| <b>4.8</b> | <b>Workers</b>               | 4.8.2 | <b><i>(Add new clause 4.8.2 as follows):</i></b><br>The Contractor shall, upon the request of the Contract Administrator, remove any person employed by them for the purposes of the Contract who, in the opinion of the Contract Administrator, is incompetent or has conducted themselves improperly, and the Contractor shall not permit a person who has been removed to return to the Place of Work.   |

- 
- |             |                             |         |  |
|-------------|-----------------------------|---------|--|
| <b>4.9</b>  | <b>Materials</b>            | 4.9.3   | <p><b><i>(Add new clause 4.9.3 as follows):</i></b><br/>The Contractor shall, at their cost,</p> <ul style="list-style-type: none"><li>a) Be responsible for storing all of the materials supplied for the Work either by themselves or the Owner, until it has been incorporated into the completed Work;</li><li>b) Store all materials in a manner which will prevent damage from the weather, dirt, foreign matter, vandalism and theft;</li><li>c) Arrange for and/or verify the time of delivery of all materials to be supplied by themselves or the Owner to ensure that delivery will coincide with their work schedules.</li><li>d) Examine with the Contract Administrator the quantities and details of all materials supplied by the Owner at the time and place of delivery or those materials already at the Place of Work, and prepare and sign a Statement of Materials Acceptance, specifically noting and rejecting any defective material;</li><li>e) Replace all materials supplied by themselves or the Owner which are found to be stolen, missing or damaged while under their care;</li><li>f) Replace all materials found to be defective in manufacture which have been supplied by themselves.</li></ul> |
| <b>4.11</b> | <b>Subcontractors</b>       | 4.11.3  | <p><b><i>(Replace clause 4.11.3 as follows):</i></b><br/>The Contractor shall, upon notice of the Contract Administrator, remove any Subcontractor employed by them for the purposes of the Contract who, in the opinion of the Contract Administrator, is incompetent or has conducted themselves improperly, and the Contractor shall not permit the Subcontractor who has been removed to return to the Place of Work. The removal of a Subcontractor under this clause shall not be considered a Change and the Contract Price and the Contract Time shall not be adjusted.</p>  |
| <b>4.12</b> | <b>Test and Inspections</b> | 4.12.1  | <p><b><i>(Replace clause 4.12.1 as follows):</i></b><br/>The Contractor shall perform or cause to be performed all tests, inspections and approvals of the Work as described in the Contract Documents or a required by the Contract Administrator as part of Quality Control. The Contractor shall complete all the necessary testing at the frequencies described in the Contract Document unless otherwise approved by the Contract Administrator.<br/>Acceptable test and inspection results will not relieve the Contractor of its obligations under the Contract to correct defects or deficiencies in the Work.</p>   |
|             |                             | 4.12.11 | <p><b><i>(Add clause 4.12.11 as follows):</i></b></p>  |

Failure to follow DFO/FLNRO BMPs and the approved permit for Instream Works or as instructed by Contract Administrator will result in shut-down of the work. The Contractor must take all steps to mitigate impacts to aquatic resources, environment and habitats before work can re-start on site. No claim will be accepted by the Owner for costs associated with this work shut-down.

**4.14 Final Clean-up**

4.14.1

***(Replace clause 4.14.1 as follows):***

Prior to applying for Substantial Performance, the Contractor shall remove all surplus products, tools, construction machinery and equipment relating to the Work that is not required for the performance of the remaining Work. The Contractor shall also remove waste, debris and waste products other than caused by the Owner or Other Contractors, and leave the Place of Work clean and suitable for occupancy by the Owner unless otherwise specified in the Contract Documents or directed by the Contract Administrator.

**4.16 Notice of Disruption**

4.16.2

***(Add new clause 4.16.2 as follows):***

Written notice must be provided to all properties which may be physically affected by the construction not less than one week and not more than two weeks prior to construction.

Notify occupants directly affected by the work 48 hours in advance of commencement of construction. Cost of notifying area occupants of ensuing construction and delivery of the notices is incidental to the Contract.

**7.0 CHANGES**

**7.1 Changes**

7.1.3

***(Replace clause 7.1.3 as follows):***

Additional work that the Owner may wished performed that does not satisfy the requirements of subparagraphs (a) and (b) of GC 7.1.1 is extra work (Extra Work) and is not a Change. Pursuant to GC 8, Extra Work may be declined by the Contractor or may, upon agreement between the parties, be undertaken as Extra Work.

**7.4 Optional Work**

7.4.2

***(Add new clause 7.4.2 as follows):***

If there are Optional items or Provisional items included in the *Schedule of Quantities and Prices*, those items shall be used only as directed and at the sole discretion of the Contract Administrator through the issue of a Change Order. These items will be paid at the contract unit price as part of regular progress payments. Only quantities used will be eligible for payment. No claim will be accepted for

unused Optional or Provisional quantities. Clause 9.4 Quantity Variations will not be applicable for these items.

**9.0 VALUATION OF CHANGES AND EXTRA WORK**

**9.2 Valuation Method** 9.2.4

***(Replace clause 9.2.4 as follows):***

Once a quotation is accepted by the Contract Administrator, or other agreement reached between the Contract Administrator and the Contractor regarding adjustments to the Contract Price or Contract Time on account of a Change or Extra Work, the Contractor shall not be entitled to claim or receive additional payment, or adjustment to the Contract Time on account of a Change or Extra Work.

**9.4 Quantity Variations** 9.4.1

***(Replace clause 9.4.1 as follows):***

If for any reason, including an addition or deletion under GC 7.1.1(1) or 7.1.1(2) respectively, the actual quantity of a unit price item varies by more than plus or minus the Variance Threshold Percentage from the estimated quantity for that unit price item listed in the Schedule of Quantities and Prices (the "Tender Quantity") or as otherwise agreed to pursuant to these Contract Documents, then either the Owner or the Contractor may by written notice request the other party to agree to a revised unit price, considering the change in quantities. A party shall make a request for a revised unit price as soon as reasonably possible after the party concerned becomes aware of the quantity variation.

9.4.2 ***(Delete clause 9.4.2 (2))***

**10.0 FORCE ACCOUNTS**

**10.1 Force Account Costs** 10.1.1(1)

***(Add to clause 10.1.1(1) as follows):***

Costs for the Contractor's Superintendent, Project Managers, Health and Safety Personnel, and Office/Administration Staff are not eligible for labour costs as those costs are considered incidental to the mark up owing for overhead and labour.

10.1.1(4) ***(Replace clause 10.1.1(4) as follows):***

Force Account Work performed by a subcontractor shall be paid for in the lesser of: (i) the amount provided by subparagraphs (1), (2) and (3) of this GC, plus a mark-up of 5%, or (ii) the actual amount the Contractor pays the subcontractor including a mark-up of 10% on such actual costs to cover all overhead and profit.

These Supplementary General Conditions must be read in conjunction with the General Conditions contained in the Master Municipal Construction Documents, Volume II, Printed 2009

**12.0 HAZARDOUS MATERIALS**

**12.2 Discovery of Hazardous Materials**      12.2.2      ***(Replace clause 12.2.2 as follows):***  
If the Contract Administrator observes any materials at the Place of Work that the Contract Administrator knows or suspects may be Hazardous Materials, then the Contract Administrator shall immediately give written notice to the Contractor and the Contractor shall immediately stop the Work or portion of the Work as required by GC 12.2.1(1).

**13.0 DELAYS**

**13.1 Delay by Owner or Contract Administrator**      13.1.2      ***(Add new clause 13.1.2 as follows):***  
The Owner may at any time suspend the work or any portion thereof provided they give the Contractor five (5) days' written notice of delay. The Contractor shall resume work upon written notice from the Owner. The Contractor shall be entitled to:

- a) An extension of the Contract time equivalent to the length of suspension of work.
- b) Reimbursement by the Owner for directly related out-of-pocket additional costs, reasonably and necessarily incurred by the Contractor as a result of such suspension. No additional payment will be made to the Contractor for any loss of profits or overhead.

**13.3 Unavoidable Delay**      13.3.1      ***(Add to clause 13.3.1 as follows):***  
Beyond the reasonable control of the Contractor also includes pandemic or community outbreak

**13.8 Direction to Stop or Delay**      13.8.3      ***(Add new clause 13.8.3 as follows):***  
The Contract Administrator may order the Contractor to stop work if at any time the Contract Administrator is of the opinion that there exists a danger to life or property.

**13.9 Liquidated Damages for Late Completion**      13.9.1      ***(Replace clause 13.9.1 as follows):***  
If the Contractor fails to meet the Milestone Date for Substantial Performance as set out in the Form of Tender, paragraph 2.2 as may be adjusted pursuant to the provisions of the Contract Documents, then the Owner may deduct from any monies owing to the Contractor for the Work:

- (1) An amount of \$1,000.00 for each calendar day the actual *Substantial Performance* is achieved after the Substantial Performance Milestone Date; plus

- (2) All direct out of pocket costs, such as costs for safety, security or equipment rental, reasonably incurred by the Owner as a direct result of such delay.

If the monies owing to the Contractor are less than the total amount owing by the Contractor to the Owner under (1) and (2) then any shortfall shall immediately, upon written notice from the Owner, and upon Substantial Performance, be due and owing by the Contractor to the Owner.

**18.0 PAYMENT**

**18.1 Preparation of Payment Certificate**

18.1.1

***(Replace clause 18.1.1 as follows):***

The Contract Administrator shall prepare and issue a certificate for the period ending the last calendar day of the month.

**18.4 Holdbacks**

18.4.2

***(Add to clause 18.4.2 as follows):***

At the sole discretion of the Contract Administrator, an amount equivalent to 10% of the contract award value or 200% of a reasonable estimate, whichever is higher, may be held without interest until all deficiencies have been remedied and accepted by the Contract Administrator.

**18.6 Substantial Performance**

18.6.5

***(Replace clause 18.6.5 as follows):***

The Owner may release any builders lien holdback on the 56th day following the date of Substantial Performance, or other date as required by law, but the Owner may hold back the amounts for any deficiencies or filed builders liens as provided in GC 18.4.2, 18.4.3 and 18.4.4.

18.6.6

***(Replace clause 18.6.6 as follows):***

The *Contract Administrator*, as defined herein, shall be the *Payment Certifier* responsible under Section 7 of the *Builders Lien Act* for certifying *Substantial Performance* of the *Work* of the *Contractor*, but not the *Work* of *Subcontractors*. The *Contractor* shall cooperate with and assist the *Contract Administrator* by providing information and assistance in a timely manner as the *Contract Administrator* considers necessary to carry out the duties of the *Payment Certifier* for the *Contract*.

The *Contractor* shall be the *Payment Certifier* responsible under Section 7 of the *Builders Lien Act* for certifying *Substantial Performance* of the *Work* of each *Subcontractor*. Prior to certifying completion for a *Subcontractor*, the *Contractor* shall consult the *Contract Administrator* and obtain the *Contract Administrator's* comments on the status of completion by the *Subcontractor*, including any

These Supplementary General Conditions must be read in conjunction with the General Conditions contained in the Master Municipal Construction Documents, Volume II, Printed 2009

deficiencies or defects in the *Subcontractor's Work* noted by the *Contract Administrator*. The *Contractor* will indemnify and save the *Owner* harmless from any and all liability the *Owner* may have to anyone arising out of the certification by the *Contractor* of *Substantial Performance* for that *Subcontractor*.

Notwithstanding any other provision of the *Contract*, no payments will be due or owing to the *Contractor* so long as a Lien filed by anyone claiming under or through the *Contractor* remains registered against the Project of any lands, or interest therein, on which *Work* for the project was performed. Failure of the *Contractor* to remove all Liens promptly will entitle the *Owner* to damages.

**19.0 TAXES, DUTIES AND  
GST**

**19.4 Tariffs or Duties**

19.4.1

Tariffs or Duties refer to taxes, levies, or charges imposed by any level of government (including foreign governments) on imported or domestic goods, materials, or equipment used in the performance of the Work. The Contract Price is based on the tariffs and duties in effect as of the date of the Tender Closing. If, after the Tender Closing Date, any new Tariffs or Duties are imposed, or existing rates are materially increased, and such changes directly and demonstrably affect the cost of materials or equipment required for the performance of the Work, the Contractor shall notify the Contract Administrator in writing within ten (10) Working Days of becoming aware of such change, providing supporting documentation, including but not limited to:

- (1) Affected materials
- (2) Quantity and cost impact
- (3) Evidence of original and new tariff rates
- (4) Reasonable efforts made to mitigate the cost impact (e.g., sourcing alternatives)

19.4.2

If the Contract Administrator is satisfied that the Contractor has incurred additional direct costs solely due to the change in Tariffs or Duties, the Owner will issue a Change Order to adjust the Contract Price accordingly. No adjustment shall be made for Tariffs or Duties that were publicly announced or reasonably foreseeable before the Tender Closing Date.

19.4.3

This clause does not apply to costs incurred due to delays caused by the Contractor's procurement or supply chain management. It also does not apply if the Contractor fails

---

These Supplementary General Conditions must be read in conjunction with the General Conditions contained in the Master Municipal Construction Documents, Volume II, Printed 2009

to take reasonable steps to mitigate the impact of the change.

- 19.4.4 If the imposition of new Tariffs or Duties causes unavoidable delays in material delivery, the Contractor may request an extension of the Contract Time under GC 13.3, subject to approval by the Contract Administrator.

**21.0 WORKERS  
COMPENSATION  
REGULATIONS**

**21.2 Contractor is  
"Prime Contractor"**

- 21.2.1 ***(Add to clause 21.2.1 as follows):***  
Prior to the issuance of the "Notice to Proceed" the Contractor must provide a signed "Prime Contractor Designation" form as provided in Appendix IV of these Supplementary General Conditions.

**24.0 INSURANCE**

***(Replace section 24.0 as follows):***

**24.1 General**

- 24.1.1 **Importance of Prompt Attention to Insurance Requirements:**  
The Contractor shall provide the Owner with satisfactory evidence that the insurance required to be provided under this GC is in full force and effect.

- 24.1.2 **Acceptable Insurance Carriers:**  
The insurer issuing any policy, or other document which is evidence of insurance to the Contractor, shall be an insurer licensed by the Superintendent of Insurance in the Province of British Columbia and registered with the Department of Insurance for Canada in Ottawa, except the Insurance Corporation of British Columbia, which is not subject to this condition.

- 24.1.3 **Owner's Right to Change Terms:**  
Notwithstanding anything contained in the Contract Documents, the Owner will have the right to request a change to the specified terms and conditions respecting insurance at the sole option of the Owner. The Contractor will be notified in writing of any changes required by the Owner and will provide a quotation for such work.

- 24.1.4 **Delivery of Insurance Documents:**  
All insurance policies or other acceptable specified documents shall be delivered to, and accepted by, the Owner before the Contract Documents are signed. No work shall be commenced by the Contractor or by anyone acting

on the instructions of the Contractor, until the required Insurance Documents have been accepted by the Owner and the Contract Documents have been duly signed by the Owner and the Contractor.

24.1.5 **Owner's Right to Insure:**

Should the Contractor for any reason not comply with the specified requirements with respect to the insurance, the Owner will, at the Owner's option, have the right to purchase all or any part of such insurance which, in the opinion of the Owner, may be required to provide the specified insurance, and, in the event of so doing, the Owner will have the right to pay the premiums for such insurance and to withhold the amount of premiums so paid from any amount due and payable to the Contractor under the Contract.

**24.2 Required Insurance**

24.2.1 **General**

Damage to work (excluding Building Contracts where Section 24.3, Paragraph 24.3.1, Further Responsibilities of Contractor, applies).

The Contractor shall be responsible for any and all loss, or damage, whatsoever which may occur on or to the works, completed or otherwise, until such time as the entire works have been completed and the Notice of Acceptance has been issued by the Owner, except that loss or damage caused solely by an act of the Owner. In the event of any loss or damage occurring, the Contractor shall, on notice from the Contract Administrator, immediately put the works into the condition it was immediately prior to such loss or damage, all at the

Contractor's expense, except where such loss or damage was caused solely by an act of the Owner.

The Contractor shall be responsible for any and all loss or damage whatsoever which may occur on or to the works, completed or otherwise, arising out of the negligence of the Contractor, any subcontractors, and the employees or agents of any of them.

24.2.2 **Public Liability Insurance:**

(Other than Automobile Third Party Liability Insurance):

**Evidence of Insurance:**

The Contractor shall deposit with the Owner, before the work commences, a Certificate of Insurance, signed by an

authorized representative of the insurer, such certificate to be as shown in Appendix III.

**Effective Dates and Terms:**

The effective date of the Certificate of Insurance shall be the date of the execution of the Contract Agreement and the term of this policy shall be from such effective date until a date not less than twelve (12) months after the date of Substantial Performance completion of all work under the Contract.

**Limits of Liability:**

For bodily injury and for property damage shall be inclusive limits not less than \$5,000,000.

24.2.3 **Public Liability Insurance (Automobile):**

The Contractor shall deposit with the Owner before the work commences a Certificate of Insurance with respect to owned automobiles on ICBC Form No. APV 47 entitled "Confirmation of Insurance Coverage" and with respect to Non-Owned Automobiles including hired automobiles and Contractual Liability on ICBC non-owned automobile policy Form APV 29 (if non-owned automobile coverage is not included under the comprehensive general liability coverage) each signed by an authorized representative of the Insurance Corporation of British Columbia.

**24.3 Physical Loss or Damage With Respect to New Buildings under Construction and/or Major Additions to Existing Structures**

24.3.1 **Responsibility for Placing Insurance:**

The types of insurance required under this section will be provided and maintained at the expense of the City of Coquitlam during the term of the Contract and will be as follows unless otherwise changed by specific endorsement to these Insurance Specifications.

24.3.2 **Insurance Coverage Required:**

Builders Risk Completed Value "All Risks" Course of Construction Insurance. This policy will be written in the names of the City of Coquitlam and the Contractor with loss payable as their respective interests may appear.

24.3.3 **Responsibility of Contractor - Limitations of cover and deductibles:**

The insurance provided by the City of Coquitlam as described herein will not provide the Contractor with full protection against any and all kinds of loss or damage which may arise out of the Contract. It is, therefore, the responsibility of the Contractor to fully understand the scope of the cover provided with particular attention to the

exclusions, limitations of cover and deductible provisions contained in the Insuring Agreements of the policies and it is further the responsibility of the Contractor to take out at the Contractor's expense, whatever other additional insurance the Contractor may consider necessary or desirable for his protection subject as hereinafter provided. The Contractor shall act in the same manner on insurance made available through the City of Coquitlam as he would if he had arranged such insurance himself.

24.3.4 **Responsibility of Contractor – Direct Damage Insurance:**

If the Contractor fails to do all or anything that is required of them concerning insurance, the City of Coquitlam may do what is required and any monies expended by the City of Coquitlam for that purpose shall be repayable and recoverable from the Contractor. Should any action, failure or negligence of the Contractor result in higher insurance costs being incurred by the City of Coquitlam, such additional costs shall be payable or recoverable from the Contractor.

24.3.5 **Responsibility of Contractor – Machinery and Equipment Belonging to Others:**

Unless otherwise directed by the City of Coquitlam in writing, the Contractor shall carry insurance covering loss or damage to construction machinery, tools and equipment owned by and/or on bare rental from a third party or parties and used by the Contractor in performing the work, which insurance shall be in a form satisfactory to the City of Coquitlam and having coverage in accordance with the actual cash value of such construction machinery, tools and equipment. Such policies shall also provide for subrogation to be waived against the City of Coquitlam. A certified copy of the policy shall be delivered to the City of Coquitlam not later than thirty days after the commencement of work under the Contract.

24.3.6 **Contractor's Waiver of Liability to Coquitlam:**

The Contractor hereby releases the City of Coquitlam from any and all liability for damages to the extent that such damages are covered by the course of construction insurance referred to in Section 24.3 of these specifications.

24.3.7 **Liability of Contractor:**

Neither the providing of insurance by the Contractor or the City of Coquitlam in accordance with the requirements hereof, nor the insolvency, bankruptcy, nor failure of any insurance company to pay any claim accruing shall be held

to waive any of the provisions of this Contract with respect to the liability of the Contractor or otherwise.

24.3.8 **Responsibility of Contractor for protection of work, persons and property:**

The Contractor and all persons employed by the Contractor or under their control, and all employees and subcontractors, shall use due care that no person or property is injured, and that no rights are infringed in the prosecution of the work. Contractors shall take particular care to protect the work against loss or damage caused by riot, vandalism or malicious mischief and shall be at the expense of the Contractor provide all necessary safeguards in the form of watchmen and/or watch dog protection to prevent loss or damage of this type. The payment of deductibles is the responsibility of the Contractor and if not paid by the Contractor such amounts shall be deducted by the City of Coquitlam from payment due to the Contractor. These deductibles will normally be \$250.00 each claim.

24.3.9 **Action to be taken in the event of loss or damage to the work covered by the Contract:**

When any loss or damage occurs to the work or to any materials and supplies on the site of the work, the Contractor shall remove any and all damaged or destroyed property and shall rebuild or replace the damaged or destroyed work, materials, or supplies and complete the work to the satisfaction of the Owner. For such removal, rebuilding, or replacing, the Contractor shall be entitled to receive from the Owner the amount of insurance monies received by the Owner pursuant to the said adjustment which amount shall be paid to the Contractor as the work of rebuilding or replacing proceeds, and in accordance with the Agreement. Damage or destruction of the whole or any part of the work shall not affect the rights and obligations of either party under the Agreement, except that in such event the Contractor shall be entitled to such reasonable extension of time to complete the work as the Architect and/or Contract Administrator may decide.

24.3.10 **Further responsibility of Contractor:**

Other than with respect to loss or damage arising out of insured risks and herein before specified, the Contractor shall be responsible for all loss or damage whatsoever which may occur on or to the works completed or otherwise, until such time as the entire works have been completed and the Notice of Acceptance has been issued by the Owner, except that loss or damage caused solely by an act of the Owner.

In the event of any loss or damage occurring, the Contractor shall on notice from the Owner immediately put the works into the condition it was immediately prior to such loss or damage, all at the Contractor's expense except as previously stated.

24.3.11 **Owner Not Responsible for Loss or Damage or Loss of Use of Property of Contractors and their Employees:**

The Owner will not be responsible for securing or paying for insurance of any kind other than as specified in Section 24.3 of these specifications nor will the Owner have any responsibility whatsoever for loss or damage from whatever cause occurring to property owned, leased, or otherwise in the possession of the Contractor, subcontractors or their employees including, without restricting the generality of the foregoing, machinery, equipment, tools, supplies, and clothing at the construction site or elsewhere including loss of use of same.

**24.4 Additional Insured** 24.4.1

**The Contractor shall ensure the following are named as "additional insured" on the liability policy for this contract:**

- The City of Coquitlam

The City may identify private properties that are directly affected by construction. If so, the Contractor shall include the legal owners of these properties named as "additional insured" on the liability policy for this contract.

**25.0 MAINTENANCE PERIOD**

**25.1 Correction of Defects** 25.1.4

***(Add new clause 25.1.4 as follows):***

The Owner is authorized to make repairs to defects or deficiencies if, ten days after giving written notice, the Contractor has failed to make or undertake with due diligence the required repairs. However, in the case of emergency where, in the opinion of the Owner, delay is not reasonable, repairs may be made without notice being sent to the Contractor. All expenses incurred by the Owner in connection with repairs made pursuant to GC 25 shall be paid by the Contractor or may be deducted from the Maintenance Security, or other holdbacks. The Contractor shall promptly pay any shortfall.

**27.0 CONTRACTOR  
PERFORMANCE  
EVALUATION**

27.1

***(Add new clause 27.1 as follows):***

After the completion of the Contract, the Contractor will be evaluated on their performance of the Work. The evaluation will provide percentage scores on the following categories:

1. *Contract Administration*
2. *Construction Management*
3. *Schedule Management*
4. *Communications*
5. *Resource Management and Contractor Performance*
6. *Quality Management*

*An evaluation summary report may be issued to the Contractor with scores for each of these categories. Upon request, the Contractor may attend a meeting with the City to discuss the evaluation.*

*This internal evaluation may be reviewed for reference on subsequent tenders with the City. Evaluation scores can form part of the tender analysis and influence contract award decisions.*

*Evaluation Scores in categories that are below 50% may result in a suspension of tendering privileges with the City.*

**APPENDIX I**

**PERFORMANCE BOND**

NO. \_\_\_\_\_ \$ \_\_\_\_\_

KNOW ALL MEN BY THESE PRESENTS THAT

\_\_\_\_\_  
As Principal, hereinafter called the Principal, and

\_\_\_\_\_  
As Surety, hereinafter called the Surety, are held and firmly bound unto

\_\_\_\_\_  
As Obligee, hereinafter called the Obligee, in the amount of

\_\_\_\_\_ Dollars  
(\$ \_\_\_\_\_ )

lawful money of Canada, for the payment of which sum, well and truly to be made, the Principal and the Surety bind themselves, their heirs, executors, administrators, successors and assigns, jointly and severally, firmly by these presents.

WHEREAS, the Principal has entered into a written contract with the Obligee, dated the \_\_\_\_\_ day of \_\_\_\_\_ 20\_\_\_\_, for

\_\_\_\_\_  
\_\_\_\_\_

in accordance with the drawings and specifications submitted, therefore, which contract, drawings and specifications and addenda thereto, to the extent provided for, are by reference made part hereof and are hereinafter referred to as the Contract.

NOW THEREFORE, THE CONDITION OF THIS OBLIGATION is such that, if the Principal shall promptly and faithfully perform said Contract (including any addenda thereto, provided such addenda do not collectively increase the amount to be paid to the Principal by more than twenty per cent (20%) of the amount of the Contract except with the written consent of the Surety) then this obligation shall be null and void; otherwise, it shall remain in full force and effect.

These Supplementary General Conditions must be read in conjunction with the General Conditions contained in the Master Municipal Construction Documents, Volume II, Printed 2009

Whenever the Principal shall be, and declared by Obligee to be, in default under the Contract, the Obligee having performed Obligee's obligations thereunder, the Surety may promptly remedy the default, or shall promptly:

1. Complete the Contract in accordance with its terms and conditions, or
2. Obtain a bid or bids for submission to Obligee for completing the Contract in accordance with its terms and conditions, and upon determination by Obligee and Surety of the lowest responsible bidder, arrange for a contract between such bidder and Obligee and make available as work progresses (even though there should be a default or a succession of defaults under the contract or contracts of completion arranged under this paragraph) sufficient funds to pay the cost of completion less the balance of the contract price; but not exceeding, including other costs and damages for which the Surety may be liable hereunder, the amount set forth in the first paragraph hereof. The term 'balance of the contract price', as used in this paragraph, shall mean the total amount payable by Obligee to Principal under the Contract less the amount properly paid by Obligee to Principal.

Any suit under this Bond must be instituted before the expiration of two (2) years from date on which the Notice of Acceptance under the Contract is issued.

The Surety shall not be liable for a greater sum than the specified penalty of this Bond.

No right of action shall accrue on this Bond to or for the use of any person or corporation other than the Obligee named herein or the heirs, executors, administrators, or successors of Obligee.

IN TESTIMONY WHEREOF, the Principal has hereto set its hand and affixed its seal, and the Surety has caused these presents to be sealed with its corporate seal duly attested by the signature of its Attorney-in-fact, this \_\_\_\_ day of \_\_\_\_\_ 20 \_\_\_\_.

SIGNED, SEALED and DELIVERED

In the presence of

)  
)  
)  
)  
)

\_\_\_\_\_  
PRINCIPAL

\_\_\_\_\_  
SURETY

\_\_\_\_\_

**APPENDIX II**

**LABOUR AND MATERIAL PAYMENT BOND**

(Private Contracts – Trustee Form)

NO. \_\_\_\_\_

\$ \_\_\_\_\_

Note: This Bond is issued simultaneously with another Bond in favour of the Obligee conditioned for the full and faithful performance of the Contract.

KNOW ALL MEN BY THESE PRESENTS THAT

\_\_\_\_\_  
As Principal, hereinafter called the Principal, and

\_\_\_\_\_  
As Surety, hereinafter called the Surety, are, subject to the conditions hereinafter contained, held and firmly bound unto

\_\_\_\_\_  
As Trustee, hereinafter called the Obligee, for the use and benefit of the Claimants, their and each of their heirs, executors, administrators, successors and assigns in the amount of

\_\_\_\_\_ Dollars  
(\$ \_\_\_\_\_) lawful money of Canada, for the payment of which sum well and truly to be made, the Principal and the Surety bind themselves, their heirs, executors, administrators, successors and assigns jointly and severally, firmly by these presents.

SIGNED AND SEALED this \_\_\_\_\_ day of \_\_\_\_\_, 20\_\_\_\_.

WHEREAS, the Principal has entered into a written contract with the Obligee dated the \_\_\_\_\_ day of \_\_\_\_\_, 20\_\_\_\_, for

\_\_\_\_\_  
\_\_\_\_\_  
which contract is by reference made a part hereof, and is hereinafter referred to as the Contract.

NOW, THEREFORE, THE CONDITION OF THIS OBLIGATION is such that, if the Principal shall make payment to all Claimants for all labour and material used or reasonably required for use in the performance of the Contract, then this obligation shall be null and void; otherwise it shall remain in full force and effect, subject, however, to the following conditions:

\_\_\_\_\_  
These Supplementary General Conditions must be read in conjunction with the General Conditions contained in the Master Municipal Construction Documents, Volume II, Printed 2009

1. A Claimant for the purpose of this Bond, is defined as one having a direct contract with the Principal for labour, material, or both, used or reasonably required for use in the performance of the Contract, labour and material being construed to include the part of water, gas, power, light, heat, oil, gasoline, telephone service or rental equipment directly applicable to the Contract provided that a person, firm or corporation who rents equipment to the Principal to be used in the performance of the Contract under a contract which provides that all or any part of the rent is to be applied towards the purchase price thereof shall only be a Claimant to the extent of the prevailing industrial rental value of such equipment for the period during which the equipment was used in the performance of the Contract. The prevailing industrial rental value of equipment shall be determined, insofar as it is practical to do so, in accordance with and in the manner provided for in the latest revised edition of the publication of the Canadian Construction Association entitled "Rental Rates on Contractors' Equipment" published prior to the period during which the equipment was used in the performance of the Contract.
2. The Principal and the Surety hereby jointly and severally agree with the Obligee as Trustee that every Claimant who has not been paid as provided for under the terms of his contract with the Principal before the expiration of a period of ninety (90) days after the date on which the last of such Claimant's work or labour was done or performed or materials were furnished by such Claimant, may as a beneficiary of the trust herein provided for, sue on this Bond, prosecute the suite to final judgment for such sum or sums as may be justly due to such Claimant under the terms of his said contract with the Principal and have execution thereon. Provided that the Obligee is not obliged to do or take any act, action or proceeding against the Surety on behalf of the Claimants or any of them to enforce the provisions of this Bond. If any act, action or proceeding is taken either in the name of the Obligee or by joining the Obligee as a party to such proceedings then such act, action or proceeding shall be taken on the understanding and basis that the Claimants or any of them who take such act, action or proceeding shall indemnify and save harmless the Obligee against all costs, charges and expense or liabilities incurred thereon and any loss or damage resulting to the Obligee by reasons thereof. Provided still further that subject to the foregoing terms and conditions, the Claimants or any of them may use the name of the Obligee to sue on and enforce the provisions of this Bond.
3. No suit or action shall be commenced hereunder by any Claimant:
  - a) unless such Claimant shall have given written notice within the time limits hereinafter set forth to each of the Principal, Surety and Obligee, stating with substantial accuracy the amount claimed. Such notice shall be served by mailing the same by registered mail to the Principal, Surety and Obligee at any place where an office is regularly maintained for the transaction of business by such persons or served in any manner in which legal process may be served in the Province or other part of Canada in which the subject matter of the contract is located. Such notice shall be given (i) in respect of any claim for the amount or any portion thereof required to be held back from the Claimant by the Principal under either the terms of the Claimant's contract with the Principal or under the Mechanic's Liens Legislation applicable to the Claimant's contract with the Principal whichever is the greater within one hundred and twenty (120) days after such Claimant should have been paid in full under the Claimant's contract with the Principal; (ii) in respect of any claim other than for the holdback or portion thereof referred to above within one hundred and twenty (120) days after the date upon which such claimant did

or performed the last of the work or labour or furnished the last of the materials for which such claim is made under the Claimant's contract with the Principal.

- b) after the expiration of one (1) year following the date on which Principal ceased work on the Contract including work performed under guarantees provided in the Contract.
- c) Other than in a court of competent jurisdiction in the Province or District of Canada in which the subject matter of the Contract or any part thereof is situated and none elsewhere, and the parties hereto agree to submit to the jurisdiction of such court.

4. The amount of this Bond shall be reduced by and to the extent of any payments made in good further and in accordance with the provisions which may be filed of record against the subject matter of the Contract, whether or not claim for the amount of such lien be presented under and against this Bond.

5. The Surety shall not be liable for a greater sum than the specified penalty of this Bond.

IN TESTIMONY WHEREOF, the Principal has hereto set its hand and affixed its seal, and the Surety has caused these presents to be sealed with its corporate seal duly attested by the signature of its Attorney-in-fact the day and year first above written.

SIGNED, SEALED and DELIVERED

In the presence of

)  
)  
)  
)  
)

\_\_\_\_\_  
PRINCIPAL

\_\_\_\_\_  
SURETY

\_\_\_\_\_

**APPENDIX III**

**CERTIFICATE OF INSURANCE**

This Certificate issued to the City of Coquitlam is to certify that policies of insurance, as described below, have been issued to the Insured named below and are in force at this time. It is understood and agreed that thirty (30) days' prior written notice by registered mail of any material alterations, transfer, assignment or cancellation of any of the policies listed below, either in part or in whole, will be given to the holder of this Certificate.

A. This Certificate is issued to: Named Insured and Mailing Address:

**City of Coquitlam**  
**3000 Guildford Way**  
Coquitlam, BC V3B 7N2

B. CONTRACT NUMBER AND/OR NAME Description of the Work:

C. INSURANCE POLICY

Name of Insurer:  
Policy Number:  
Effective Date:

Liability Limit:  
Expiry Date:

D. INSURANCE COVERAGE

**COMMERCIAL GENERAL LIABILITY** coverage is required to insure against liability from the activities arising out of operations or work in connection with the above-described project, including liability arising out of the use of City property.

D.1 The minimum limit shall be \$5,000,000.00 inclusive per occurrence against bodily injury, personal injury and property damage.

D.2 The City of Coquitlam, its employees, officers, agents and volunteers are added as Additional Insureds, but only with respect to operations conducted by or on behalf of the Named Insured in connection with the above-described project, operations or work.

D.3 This insurance shall be primary as regards the City of Coquitlam, its employees, officers, agents and volunteers as Additional Insureds.

D.4 Any deductible or reimbursement clause contained in the policy shall not apply to the City of Coquitlam and shall be the sole responsibility of the Named Insured.

D.5 The insurance shall include the following coverages:

- D.5.1 Cross Liability Clause
- D.5.2 Non-Owned Automobile Liability
- D.5.3 Unlicensed Automobile Liability
- D.5.4 Blanket Contractual Liability
- D.5.5 Broad Form Property Damage Liability
- D.5.6 Owner's & Contractor's Protective Liability
- D.5.7 Products & Completed Operations Liability

D.6 Indicate provision of special coverage for this project as required by the City:

YES	NO	Special Coverage Description
-----	----	------------------------------

- |     |       |                                 |
|-----|-------|---------------------------------|
| ( ) | ( X ) | Shoring and Underpinning Hazard |
| ( ) | ( X ) | Pile Driving and Vibrations     |
| ( ) | ( X ) | Excavation Hazard               |
| ( ) | ( X ) | Demolition                      |
| ( ) | ( X ) | Blasting                        |

\_\_\_\_\_  
Authorized Signature and Stamp

\_\_\_\_\_  
Date

\_\_\_\_\_  
Name and Title

\_\_\_\_\_  
City' broker to return to City Representative

\_\_\_\_\_  
Department

These Supplementary General Conditions must be read in conjunction with the General Conditions contained in the Master Municipal Construction Documents, Volume II, Printed 2009



**APPENDIX IV**

**PRIME CONTRACTOR DESIGNATION**

Owner: **City of Coquitlam**  
Contractor: \_\_\_\_\_  
Contract / Permit #: **79058**  
Project / Workplace: **Clarke & Glenayre and Lougheed & Woolridge Intersection Improvements**  
(the "Project")

By signing this Prime Contractor Designation form, the Contractor hereby:

1. agrees to be, and accepts designation as, the "prime contractor" for the purposes of the Workers Compensation Act, R.S.B.C. 2019, c. 1 (the "Act") and the Occupational Health and Safety Regulation, B.C. Reg. 223/2022 (the "Regulation") in respect of the Project and Workplace noted above;
2. represents and warrants that the Contractor is qualified and capable to perform the duties of prime contractor and that the undersigned signatory has the authority to accept designation as prime contractor and to bind the Contractor;
3. accepts the duty and responsibility for ensuring the activities of employers, workers and other persons at the Workplace relating to occupational health and safety are coordinated and agrees to do everything that is reasonably practicable to establish and maintain a system or process that will ensure compliance with the Act and the Regulation in respect of the Workplace;
4. covenants and agrees to comply with the occupational health and safety provisions of the Act, the Regulation, any other applicable regulations under the Act, and any applicable orders;
5. acknowledges and agrees that the Owner has provided the Contractor the information known to the Owner that is necessary to identify and eliminate or control hazards to the health or safety of persons at the Workplace; and
6. agrees that the designation as prime contractor hereunder may not be assigned or revoked without the prior written consent of the Owner.

**Prime Contractor Name:** \_\_\_\_\_

**Prime Contractor Address:** \_\_\_\_\_

\_\_\_\_\_  
**Prime Contractor Signature** **Date**

\_\_\_\_\_  
**Print Name**

*Please return a signed copy of this designation to the City of Coquitlam, 3000 Guildford Way, Coquitlam, BC, V3B 7N2. If you have any questions, please contact the City of Coquitlam Health & Safety Manager at 604-927-3070.*

These Supplementary General Conditions must be read in conjunction with the General Conditions contained in the Master Municipal Construction Documents, Volume II, Printed 2009

# ***Supplementary Contract Specifications***

**Supplementary Contract Specifications**

to the  
MASTER MUNICIPAL SPECIFICATIONS  
**Volume II – Platinum Book**

**Clarke & Glenayre and Lougheed & Woolridge Intersection Improvements**

CONTRACT 79058

**TABLE OF CONTENTS**

The following Supplementary Specifications are to be considered part of the Specifications. These Supplementary Specifications take precedence over the Master Municipal Specifications.

**SUPPLEMENTARY CONTRACT**

<b>SUPPLEMENTARY CONTRACT SPECIFICATIONS INDEX .....</b>	<b>SS 1</b>
00 72 43S Contract Specific Notations .....	SS 2 to SS 5
01 33 01S Project Record Documents .....	SS 6
01 45 00S Quality Control .....	SS 7 to SS 9
01 55 00S Traffic Control, Vehicle Access and Parking.....	SS 10 to SS 11
01 57 01S Environmental Protection .....	SS 12 to SS 13
01 58 01S Project Identification .....	SS 14
03 30 20S Concrete Walks, Curbs and Gutters.....	SS 15 to SS 16
31 05 17S Aggregates and Granular Material .....	SS 17
31 11 01S Clearing and Grubbing.....	SS 18
31 23 01S Excavating, Trenching and Backfilling.....	SS 19
31 24 13S Roadway Excavation, Embankment and Compaction .....	SS 20 to SS 21
32 01 16.7S Cold Milling.....	SS 22
32 11 16.1S Granular Subbase .....	SS 23
32 11 23S Granular Base .....	SS 24
32 12 13.1S Asphalt Tack Coat .....	SS 25
32 12 16S Hot-Mix Asphalt Concrete Paving.....	SS 26 to SS 28
32 17 23S Painted Pavement Markings.....	SS 29 to SS 31
32 31 13S Chain Link Fences and Gates .....	SS 32
32 84 23 Irrigation.....	SS 33 to SS 52
33 40 01S Storm Sewers .....	SS 53 to SS 56
33 44 01S Manholes and Catchbasins.....	SS 57 to SS 59
34 41 13S Traffic Signals.....	SS 60 to SS 69

CONTRACT SPECIFIC NOTATIONS

**1.00 CONTRACT SPECIFIC INSTRUCTIONS**

**1.01 Schedule of Work**

All work under this Contract is to be completed by the designated Substantial Performance Date as described in the Contract Documents. The Contractor must provide sufficient resources in a continuous effort and site presence to complete all the work within the allotted time. As set out in the MMCD, the Contractor must provide updates to the construction schedule biweekly.

**1.02 Coordination of Work**

The Contractor shall be responsible to consult with all affected businesses, residents, transportation companies regarding delays, detours, and any other works affecting any transit service in the area, and will be responsible to coordinate the works with City crews and other contractors working in the area. If working area is to become a multiple-employer workplace as defined by WorkSafe BC, the Contractor shall remain the Prime Contractor.

**1.03 Outside Agency Approval**

In accordance with the Contract Documents, the Contractor is responsible to consult with and obtain any approval required to meet and comply with all the conditions required from outside agency such as, but not limited to, BC One Call, Metro Vancouver, BC Hydro, Telus, Kinder Morgan, Fortis BC and Translink in the area of the place of Work. City has approached Fortis, BC Hydro and Translink and have obtained necessary permits. Please refer to Appendix B for the permits obtained and detailed instructions from Fortis BC, BC Hydro and Translink for other approvals Contractor has to obtain.

**1.04 Waste Collection Coordination**

Contractor is responsible to accommodate all waste collection vehicles and cart pick up schedules throughout construction. .

Questions: [wastereduction@coquitlam.ca](mailto:wastereduction@coquitlam.ca)

**1.05 Cooperation with Emergency and Maintenance Activities**

The Contractor will be responsible to cooperate with regular maintenance or emergency vehicles and staff for access to the site when required including:

- Fire, Police, and Ambulance
- Collections (garbage/recycling pick-up)
- City Utilities Maintenance (or representatives)
- Other Contractors

**1.06 Site Safety**

The Contractor is responsible to ensure the construction site is safe at all times for workers, pedestrians, and vehicle traffic. During non-working hours, the Contractor must ensure that the site has all potentially hazardous areas appropriately identified and protected, and also must provide appropriate signage, lighting, and markings for the direction of vehicle and pedestrian traffic, all to ensure the safety of the public. Supply and use of this equipment is considered incidental to the contract.

Manhole lids, valve boxes and other appurtenances within the roadway that may present a traffic hazard during construction must be clearly marked for traffic.

Manhole lids left raised in preparation for paving must have a rubberized protector ring painted with bright colour for traffic safety. Supply and use of this equipment is considered incidental to the contract.

**1.07 Lane Closure Restrictions**

The contractor shall refer to Contract Supplementary Specifications Section 01 55 00S and to Appendix A: Traffic Management Detail Specifications.

The Contractor must take the above information into account in the preparation and submission of the Tender.

**1.08 Survey Layout**

Construction layout will be the responsibility of the Contractor.

CONTRACT SPECIFIC NOTATIONS

- 1.09 Location of Existing Utilities**
- The contractor is responsible to verify the depth and location of all utilities (watermains, storm mains, sanitary mains & etc.), including outside agency utilities (i.e. MV, Fortis BC Gas Mains & etc.) and service connections (water, storm & sanitary services at the mains & property lines) by hand digging or by Hydro-Vac in the presence of the Inspector.
- Pre-locates must be completed as soon as possible after award of the contract so changes can be completed by the Engineer prior to site construction. Contact Metro Vancouver for location of their utilities and BC One for location of other outside agency utilities. The contractor will not receive any compensation or allowance for delays if work is halted due to utilities & services connections not located prior to commencing construction.
- City of Coquitlam does not guarantee water, storm or sanitary services connections are perpendicular to the mains or property lines, the contractor will not receive any compensation for the time to locate these connections or for exposing hidden services at the property lines.
- Payment for this work will be treated as incidental to payment for work described in other Sections.
- 1.10 Manholes & Valves**
- Access to manholes and valves must be maintained at all time for city utilities crews and external utility companies. In case of an emergency the cost for exposing any buried manhole or valve covers during construction will be paid by the contractor.
- 1.11 Verification of Dimensions and Quantities**
- Before proceeding with work, the Contractor shall visit the site, and check and verify dimensions and quantities. Report variations between drawings and site conditions to the Contract Administrator before proceeding with work. Payment for this work will be treated as incidental to payment for work described in other Sections.
- 1.12 Precautions**
- Protect areas under construction from damage caused by excessive erosion, flooding, heavy rains, etc. Repair or replace unprotected damaged areas as directed by the Contract Administrator at no cost to the Owner.
- 1.13 Work by Others**
- The Contractor is required to accommodate the City crews, Contractors, Developers and Utility companies in their scheduling and sequencing of work at no cost to the Owner.
- 1.14 FORTIS BC Emergency Protocol**
- In an emergency, gas pipeline rupture or leak, Contact Fortis BC 24 Hour Emergency Line (1-800-663-9911) & Fire Department (911) immediately and then City Coquitlam Utility Control Centre (604-927-6287).
- 1.15 Temporary Asphalt Pavement Restoration**
- The Contractor will be required to backfill all trenches (in paved areas) and place a temporary patch (50mm of hot mix asphalt), as per Coquitlam Standard Drawing COQ-G4, the same day excavation is made, unless otherwise approved by the Contract Administrator.
- 1.16 Order of Construction**
- The Contractor will be required to conduct the work as approved by the Contract Administrator in a manner causing minimum disturbance to general public, traffic and nearby residents and businesses.
- 1.17 Approved Materials**
- Refer to the City of Coquitlam website at <https://coquitlam.ca/263/Subdivisions> for the List of Approved Materials and Products which are to be incorporated
- 1.18 As Built Record Drawings**
- As built record drawings for City of Coquitlam are available in QtheMap, the City of Coquitlam's online interactive map (<http://coquitlam.ca/QtheMap>).
- 2.00 CONSTRUCTION ACTIVITY**

CONTRACT SPECIFIC NOTATIONS

**2.01 Construction Materials in Sewer Manholes and Pipe**

The Contractor is responsible to ensure that construction activities do not deposit construction materials (e.g. gravels) into the storm sewer or sanitary sewer manholes or pipe. The City has a video record of the pipe before construction. Prior to Substantial Performance, the City may again video inspect the lines to ensure no problems exist due to construction activities under this contract. If problems are encountered, the Contractor will be responsible for the cost of the video and all costs associated with the cleaning of the pipe.

**2.02 Site Clean-up During Construction and End of Construction**

The Contractor will be responsible for the complete clean up of the work site during construction & at the end of construction and prior to the Substantial Performance review. This work is considered incidental to the Contract.

The work will include cleaning of all catch basins periodically or as directed by the Contract Administrator within the Work area, or nearby location as affected by the Work, to the same or better condition of the catch basins prior to starting the Work. All cleaning is to be performed by vacuum truck to the satisfaction of the Contract Administrator and will include off-site disposal of waste material. Payment for this work will be treated as incidental to payment for work described in other Sections.

**2.03 Asphalt Milling Operations**

Asphalt milling activities shall be done in such manner so as to cause the least disruption and inconvenience to traffic and area residents.

The Contractor will be required to provide a plan and schedule for milling sections and the subsequent paving activities and have that approved by the Contract Administrator. This schedule is to be updated as required and take into consideration weather conditions and weather forecasts to ensure work subsequent to milling can be completed in appropriate weather.

**MILLING OF EXTENSIVE AREAS THAT CANNOT BE PAVED WITHIN 48 HOURS PERIOD (2 DAYS) WILL NOT BE PERMITTED.**

**3.00 MANDATORY MEETINGS AND CONTRACTOR REPRESENTATIVES AND SUBCONTRACTORS**

**3.01 Pre-Construction Meeting Requirements**

After the Award of the Contract, the Contractor (Project Manager & Superintendent) will be required to attend a Pre-Construction Meeting with the Contract Administrator and provide all necessary information required by the Contract Administrator prior to provision of a Notice to Proceed. Items required to be provided at the meeting include:

1. A Detailed Construction Schedule showing the start date & completion date and the durations of major work components showing how all work will be completed within the Contract Duration.
2. Proof of insurance
3. Performance Bond and Labour and Materials Payment Bond
4. WCB Clearance Letter and copy of Notice of Project
5. City of Coquitlam Business License
6. A copy of portions of your Health and Safety Plan including the Title Page, Table of Contents, and portion showing latest revision date.

**3.02 Contract Schedule, Contract Duration, and Charges**

A detailed, realistic construction schedule for this project must be presented at the pre-construction meeting. The schedule must show major components and durations.

All work under this project is to be completed within the designated Contract Duration as contained in the signed Contract Agreement, or as formally amended.

**3.03 Contract Superintendent  
and Subcontractors**

In compliance with the MMCD General Conditions, Section 4.7, Superintendent, the Contractor shall have a competent senior representative, (the "Superintendent") in FULL TIME attendance at the Place of Work while work is being performed for the duration of the contract.

This (FULL TIME) attendance is also required when Subcontractors are performing work.

Work done by Subcontractors is to be directed by the Superintendent and monitored on site ensuring conformance to the Contract Documents and other particular direction to the Superintendent by the Contract Administrator.

The Owner and Contract Administrator are not responsible for the direction of Subcontractors.

**3.04 Pre-Paving  
Site Meeting**

The Contractor will be required to have a pre-paving meeting with their paving staff, on-site, just prior to paving to provide instruction regarding the existing grading and requirements for the paving process and the product.

The Contractor must provide information to the Contract Administrator, for review, regarding proposed paving elevation control method, mat thickness control method, and rolling patterns.

The Contractor Administrator must be in attendance at this meeting. It will be the responsibility of the Contractor's Contract Superintendent to ensure continuity between the base preparation and the paving process.

**3.05 Changes of Contractor  
Representatives &  
Subcontractors**

The Superintendent and Subcontractors indicated in the Form of Tender shall not be changed unless:

1. The Owner requests a replacement.
2. The Contractor submits an application for a change, in writing, to the Contract Administrator with the change being approved in writing.

**3.06 Mobilization and  
Demobilization**

Payment for mobilization and demobilization of all equipment, labour and materials (both from the Contractor and from all sub-contractors) shall be incidental.

**END OF SECTION**

**1.0 GENERAL**

**1.3 Submission**

Delete 1.3.2 and  
replace with the  
following

Submit one copy of an accurate project record document in final form prior to applying for Substantial Performance including any video report, test reports and Operation & Maintenance manual. Record documents to include changes in the Issued for Construction Drawings, new elevation, offsets & location of all utilities, manhole rim, catchbasin rim, vaults, valve boxes, inverts walkways/sidewalks, and any unknown/new utilities found on site. Legal holdbacks will not be released until complete record documents, including record drawings and O&M manuals, have been submitted and accepted by the Contract Administrator.

Contractor to get sign off letter duly signed by the property owners when private side is affected by the work. Properties to get the sign off letters will be at the sole discretion of the Contract Administrator.

Payment for all work performed under this section will be incidental to work in other Sections, unless otherwise described in Schedule of Quantities and Prices.

**END OF SECTION**

QUALITY CONTROL

- 1.0 QUALITY**
- The Contractor shall provide a final product conforming to the Contract Documents and the intent of the work.
- The work is to be accurate to the dimensional and tolerance requirements of the contract.
- Payment will be subject to adjustments based on quality assurance tests performed by the Contract Administrator.
- 1.1 Quality Control (QC) by Contractor**
- The MMCD (2009) definition of "Quality Control" is the process by which the Contractor checks specific materials, products, and workmanship to ensure strict conformance with the Contract Documents.**
- The Contractor is fully responsible for quality control of the materials, production, and construction processes.
- Quality control tests shall be performed by the Contractor, at their own expense, to ensure that products meet the contract specifications.
- Failure by the Contractor to conduct adequate quality control testing during production and construction will negate the Contractor's ability to appeal the quality assurance tests used for acceptance/rejection of the work.
- Under no circumstances will QC test results produced after completion of the Quality Assurance (QA) results be considered for appeal purposes.
- Any changes in the Work with respect to the location, grade, or line shall be approved in advance by the Contract Administrator. Failure to notify the Contract Administrator of changes in writing may result in rejection of Work.
- 1.2 Inspection of Work, Quality Assurance, and Material Testing, by the Owner**
- The MMCD (2009) definition of "Quality Assurance" means the process by which the Owner evaluates if the work is being constructed in accordance with the Contract Documents. This definition will be used for this contract**
- The *Contract Administrator* may provide construction review through spot inspections and spot materials testing for Quality Assurance.
- Any materials testing results indicating a non-conformance to the Contract Documents will require construction corrective action by the Contractor.**
- All subsequent testing to corrective action to verify conformance to the Contract Documents will be the full responsibility of the Contractor.**
- Inspection review by the Owner will not relieve the Contractor from providing a product that meets or exceeds the requirements of the Contract Documents.
- 1.3 Inspection**
- Materials testing shall be as described in MMCD General Conditions, Section 4.12 with the following change:
- Delete Section 4.12.2(a) and insert the following:
- Where the MMCD specification clauses for Inspection and Testing indicate the Contract Administrator will arrange for all testing for work described in this section will be amended to read The Contractor will arrange for and pay for all testing for work described in this section. The testing shall take place at the following prescribed rates and as directed by

QUALITY CONTROL

the Contract Administrator. The Contract Administrator has the authority to call for testing, up to the rates and frequencies specified, at the Contractors cost.

All testing covered under this item shall be performed by a CCIL certified laboratory and technicians with copies of all test results to be sent directly to the Contract Administrator. Re-testing resulting from failed first tests shall be at the Contractors expense.

**1.4 Survey Layout**

The Contractor shall be responsible for all survey layouts unless otherwise described in the document. All Survey Layout to be completed in accordance with the Contract Drawings and Coordinate System set out within them. The Contractor will be provided digital AutoCAD files but shall be responsible to confirm elevations and tie in locations and report any discrepancies prior to construction.

The Contractor shall be responsible for the preservation of all layout stakes and marks. If at any time during the progress of the work any error shall appear or arise in the position, levels, dimensions or alignment of any part of the work, the Contractor shall stop work on his portion of the project and shall notify the Contract Administrator. The Contractor shall make all the necessary corrections required.

**1.5 Testing**

Contractor shall carry out inspection and testing (QC) to ensure compliance with Contract Documents. Contractor shall submit test results within one week of testing to the Contract Administrator. The Contractor shall provide test results prior to the preparation of the payment certificate.

**1.6 Contractors Responsibilities**

Furnish labour and facilities to:

1. Provide access to work to be inspected
2. Facilitate inspections and tests
3. Make good work disturbed by inspection and tests

**1.7 Access to Work**

Allow inspection testing agencies access to Work.

**1.8 Tests**

Test rates and frequencies (excluding failed tests), when not defined in the MMCD or Detail Specifications Sections shall be at the following frequencies:

1. Trench Backfilling and Compaction

1.1 Compaction: 1 test / 10 lm / 300mm lift

1.2 Sieve: 1 test / placed material / 50 m<sup>3</sup>

2. Granular Base

2.1 Compaction: 1 test/500m<sup>2</sup> / 100mm depth of granular base, min. 1 test if < 500m<sup>2</sup>

2.2 Sieve: 1 test / placed material / 250 TONNES

3. Granular Subbase

3.1 Compaction: 1 test/500m<sup>2</sup>/150mm depth of granular subbase, min. 1 test if <500m<sup>2</sup>

3.2 Sieve: 1 test / placed material / 250 TONNES

4. Embankment (Subgrade)

4.1 Compaction: 1 test/ 50m<sup>2</sup> / 0.15m depth of fill, min. 1 test if < 50m<sup>2</sup>

4.2 Sieve: 1 test / placed material / 100 TONNES

5. Asphalt

5.1 Marshall test: 1 test per 250 TONNES placed, per mix specified, min. 1 / day  
ASTM D1559, D3203, C117, C136

5.2 Superpave: 1 test per 250 TONNES placed, per mix specified, min. 1 / day

**QUALITY CONTROL**

CAI-SP2, ASTM D3203, C117, C136

5.3 Cores: 1 per 500 m<sup>2</sup>/lift

5.4 Continuous asphalt density testing during paving.

6. Subgrade Preparation

6.1 Compaction & Moisture: 1 test / 500 m<sup>2</sup>, min. 1 test if < 500m<sup>2</sup>

7. Concrete Tests

7.1 Air, Slump & 1 Set Cylinders: 1 test / 10 m<sup>3</sup>, min. 1 set / day

Mix design, sieve analysis and all required reports to be submitted must be recent and dated within six months prior to construction.

**1.9 Measurement for  
Payment**

Payment for all work performed under this section will be incidental to payment for work described in other Sections.

**END OF SECTION**

<b>1.0</b>	<b>GENERAL</b>	Add 1.0.6	<p>The <i>Contractor</i> is responsible for all temporary traffic control on the streets required for completion of the work. The <i>Contractor</i> will be responsible to provide a Traffic Management Plan (TMP) for approval (10) ten working days prior to any lane closures taking place. TMP is to be prepared by a qualified professional to the satisfaction of the Contract Administrator.</p> <p>The TMP shall outline the approach to traffic management, show recognition and minimization of risks indicates signing locations, identify Traffic Control Persons (TCP) stations, show lane shifting and proposed closures.</p> <p>The Contractor is responsible to ensure and maintain all business/residential vehicles, cyclists and pedestrian accesses open at all times. The contractor may provide temporary accesses if the affected owner agrees. All costs associated with temporary accesses will be at the contractor's expense.</p>
		Add 1.0.7	<p>A Road and Sidewalk Closure Permit is required from Coquitlam for all work affecting pedestrian and traffic flow related to construction. A permit is required for each specific construction interference with pedestrian and traffic flow. The road and sidewalk closure permit form can be obtained for use from the City's website at <a href="http://www.coquitlam.ca">http://www.coquitlam.ca</a>. The Contractor must follow the approved TMP. Any changes to this TMP must be submitted to Traffic and Street Use Management for approval.</p>
		Add 1.0.8	<p>Refer to Appendix A – Traffic Management Detail Specifications.</p>
		Add 1.0.9	<p>The Contractor is responsible to maintain all business/residential vehicles and pedestrian accesses open at all times, the contractor may provide temporary accesses if the affected owner agrees. All costs associated with temporary accesses will be at the contractor's expense.</p>
<b>1.4</b>	<b>Traffic Control</b>	Delete 1.4.1 and replace with the following	<p>The Contractor shall conduct his operations to cause the minimum obstruction and inconvenience to traffic and to places of business and residences adjacent to the Place of Work. No greater quantity of work shall be undertaken at any one time than can be properly conducted with due regard to the rights and interests of the public as may be determined by the Contract Administrator.</p> <p>The Contractor is to provide at all times safe and convenient means of approach and entrance to adjoining lanes, driveways, buildings and property both for vehicles and pedestrians to the satisfaction of the Contract Administrator. For this purpose, he shall construct and maintain suitable and safe platforms, approaches, structures, bridges, diversions or other works.</p> <p>Where traffic must cross open trenches, the Contractor shall provide suitable bridges. Where trenches have been backfilled or where road improvements are incomplete, the Contractor shall take any steps necessary to prevent potholes or other traffic hazards. Where the Contract Administrator so instructs or where Contract Specifications so require, the Contractor shall provide temporary asphalt patching of such hazards.</p>

Add 1.4.9.3.1                      The *Contractor*, as required by the *Contract Administrator* and the City, is to supply Construction Zone information signs (stationary) or Changeable Message Signs refer to MMCD 01 58 01 for the required identification signage.

The *Contractor* is responsible for the removal of the signs at the completion of the work.

Delete 1.4.10.1.3 and  
replace with the  
following                      When workmen or equipment are employed over travelled way over brow of hills, around sharp curves or at other locations where oncoming traffic would not otherwise have adequate warning.

**END OF SECTION**

1.0 GENERAL

1.0.3 Erosion and Sediment Control Supervisor

Add 1.0.3

The Erosion and Sediment Control (ESC) Supervisor is the Qualified Professional, who is experienced in implementing ESC Plans and who is responsible for the inspection and monitoring of ESC Facilities to ensure these are installed and maintained and if necessary, are modified during construction to ensure compliance with the Stream and Drainage System Protection Bylaw No. 4403, 2013.

1.2 Temporary Erosion and Sediment Controls

Delete 1.2.1 and replace with the following

Properly drain all portions of the site. Protect the site and the watercourses to which it drains, directly or indirectly, against erosion and siltation in accordance with a Sediment Control Plan under the City of Coquitlam Stream and Drainage System Protection Bylaw No. 4403, 2013 during construction and until the maintenance period is completed. Ensure no silt, gravel, debris or other deleterious substance resulting from construction activity discharges into existing drainage systems or watercourses or onto highways or adjacent property. The *Contractor* is responsible for all damage that may be caused by water backing up or flowing over, through, from or along any part of the work or otherwise resulting from his operations.

Keep existing culverts, drains, ditches and watercourses affected by the work clear of excavated material at all times. When it is necessary to remove or alter any existing drainage structure, provide suitable alternative measures for handling the drainage. Adequately support culverts and drainpipes across trenches to prevent displacement and interference with the proper flow of water due to trench settlement.

Sweep streets, and clean catch basins, manhole sumps, detention tanks, and maintain siltation controls as often as the *Contract Administrator* and the City deems necessary.

Delete 1.2.2.2 and replace with the following

Do not operate construction equipment in watercourses.

Add 1.2.2.9

All work must be carried out during favorable and low water conditions.

Add 1.2.2.10

Any fill used on this project shall be certified inert and from a source which is confirmed to be free of contaminants.

Add 1.2.2.11

All work within a watercourse must be undertaken and completed in isolation of all flowing water to maintain downstream water quality and unrestricted flows.

1.4 Environmental Protection

Add 1.4.3.5

Immediately contain and clean up any leaks and spills of prohibited materials at the *Place of Work*.

Add 1.4.3.6

Ensure that a well-stocked spill kit is on-site at all times and that the *Contractor's* employees are familiar with appropriate spill response techniques.

Add 1.4.3.7

Immediately notify the *Contract Administrator* and the City of any leaks or spills of prohibited materials that occur at the *Place of Work*.

		Add 1.4.3.8	Ensure that any fuel stored on-site is located at least 15 meters from the nearest stream, and is placed within a bermed and lined area, in order to prevent leaks or spills into the environment.
		Add 1.4.3.9	All equipment and machinery must be in good working condition (power washed), free of leaks or excess oil and grease. No equipment refueling or servicing shall be undertaken within a minimum of 15 meters of any watercourse or surface water drainage.
		Add 1.4.3.10	During all phases of the operation, the Contractor shall take precautions to abate nuisance caused by mud or dust by clean up, sweeping, sprinkling with water or dust control, or other means as necessary to accomplish results satisfactory to the Contract Administrator.
<b>1.6</b>	<b>Measurement and Payment</b>	Delete 1.6.1 and replace with the following	Payment for all work, unless included in the Schedule of Quantities and Prices, performed under this section will be incidental to payment for work described in other Sections.
		Add 1.6.2	Payment for the poly cover or temporary tarps over stockpile materials or exposed road subgrades shall be treated as incidental work.
<b>1.9</b>	<b>Archaeological / Historical Resources</b>	Add 1.9 .1	If any archaeological or historical resources are encountered during construction, work must cease immediately. The Contractor shall promptly notify the Contract Administrator and the City. All such resources shall be left in place and must not be disturbed under any circumstances. The Contractor shall comply with the procedures outlined in Appendix E: Archaeological Chance Find Procedures.

**END OF SECTION**

**PROJECT IDENTIFICATION**

---

**1.3 Measurement and  
Payment**

Delete 1.3.1 and  
replace with the  
following

Payment for the installation of 1.2m x 1.2m static construction  
Information signs as shown in Appendix A – Traffic Management  
Detail Specifications - Clause 6.5 includes supply, placement &  
removal and will be incidental to payment for work described in  
other Sections, unless shown otherwise in the Schedule of  
Quantities and Prices.

Add 1.3.2

Payment for changeable message signs (CMS) includes supply,  
placement, and removal.

**END OF SECTION**

CONCRETE WALKS, CURBS AND GUTTERS

<b>1.4</b>	<b>Measurement and Payment</b>	Delete 1.4.3 and replace with the following	<p>Payment for machine placed or hand formed C5/C4 wide base and median narrow concrete curb and gutter, includes supply and placing of the concrete curb and gutter, tie-ins, transitions, subgrade preparation, compaction, saw cutting, and will cover all straight and curve sections and will be made separately for each specified type.</p> <p>Payment for excavation and disposal of excavated material will be made under payment item, Common Excavation – offsite disposal, in the Schedule of Quantities and Price.</p> <p>Payment for granular subbase and granular base under curb and gutter will be made under payment items in Section 32 11 16.1S and 32 11 23S, Granular Subbase and Granular Base, respectively.</p>
		Delete 1.4.5 and replace with the following	<p>Payment for concrete sidewalks, letdowns, driveways, walkways, raised concrete islands, stamp concrete, infills, concrete exposed aggregate and all concrete ramps, supply and installation, saw cutting, regrading of driveways for proper tie-in, field fit and adjustments, subgrade preparation under the concrete sidewalks, in-fills, driveways and walkways, and will be made separately for each specified thickness and type of finish.</p> <p>Payment for excavation and disposal of native excavated material will be made under payment item, Common Excavation – offsite disposal, in the Schedule of Quantities and Price.</p> <p>Payment for granular subbase and granular base will be made under payment items in Section 32 11 16.1S and 32 11 23S, Granular Subbase and Granular Base, respectively.</p>
		Add 1.4.10	<p>Payment for Detectable/Tactile Warning Surface Tile includes supply and placing of Access Tile Model # ACC-R-_x_ (or approved equal) Truncated Dome Detectable Warning Tactile Surface replaceable cast in place - Yellow Color, installation as per the Manufacture’s Specifications and as specified in the Schedule of Quantities and Prices.</p>
		Add 1.4.11	<p>Payment under this item will include supply and complete installation of TYPE R-7901 bollards as per Burquitlam Lougheed Streetscape guideline. Mounting Option would be “Removable Receiver with Lid’.</p> <p><a href="https://www.coquitlam.ca/DocumentCenter/View/364/Burquitlam-Lougheed-Streetscape-Guidelines-PDF">https://www.coquitlam.ca/DocumentCenter/View/364/Burquitlam-Lougheed-Streetscape-Guidelines-PDF</a></p>
<b>2.1</b>	<b>Materials</b>	Delete 2.1.5.1 and replace with the following	<p>Hand-formed and hand-placed concrete:</p> <p>Slump: 80 mm Air entrainment: 5 to 8%. Maximum aggregate size: 20 mm. Minimum cement content: 335 kg/m3. Minimum 28-day compressive strength: 32 MPa.</p>
		Add 2.1.7	<p>Tactile warning surface tile shall be replaceable cast-in-place style. truncated domes shall be in square grid pattern with a 5 mm nominal raised height, base diameter of 23 mm and top diameter of 11.5 mm. Dome spacing range shall be between 40 mm – 60 mm.</p> <p>Color of the panel shall be Federal Yellow (Y) per US Federal Standard 595B Table IV, Color No. 335.</p>

Minimum size of the panel shall be 600 mm by 1200 mm.

**3.0 EXECUTION**

**3.5 Concrete Placement**

Delete 3.5.9 and  
replace with the  
following

The *Contractor* is responsible for adjusting all utility manhole frames and valve boxes, belonging to Coquitlam and/or other agencies that are affected by the road works. All adjustments to utilities must be completed to the satisfaction of the utility owner. Riser rings will not be accepted.

The *Contractor* should note that certain utility owners may decide to complete their own adjustments. The *Contractor* will be required to cooperate with any utility company providing their own adjustments.

The *Contractor* shall be responsible to contact the appropriate utility company within a minimum of seventy-two (72) hours of the work. No adjustment shall be made without the written approval of the utility company. All manholes must be vertically adjusted a minimum of twenty-four (24) hours prior to concrete placement.

**3.9 Expansion Joints**

Delete 3.9.1 and  
replace with the  
following

Form transverse expansion joints at both ends of curb returns and at maximum spacing of 9.0 m for sidewalks, 30.0 m of curb and gutter, at each end of driveway crossing, at tangent point of circular work, and on either side of catch basins.

**END OF SECTION**

**2.0 PRODUCTS**

**2.3 Pit Run Gravel**

Add to 2.3.2

The use of recycled concrete shall be approved by the *Contract Administrator* and the City prior to use.

Add 2.3.3

Asphalt millings free from contaminated and other extraneous material, conforming to the specified gradations may be used as pit run gravel. The use of asphalt millings shall be approved by the *Contract Administrator* and the City prior to use.

**2.7 Granular Pipe Bedding and Surround Material**

Add to 2.7.1

All recycled or other extraneous materials shall be approved by *Contract Administrator* and the City prior to use.

**2.10 Granular Base**

Delete 2.10.2

Add 2.10.3

All 25 mm minus granular base is to conform to the following gradation specifications for Collector / Arterial Roads:

Sieve Designation (mm)	Percent Passing (%)
25	100
19	80-100
12.5	75-90
9.5	50-85
4.75	35-70
2.36	25-50
1.18	15-35
0.30	5-20
0.075	0-5

Add 2.10.4

The intention of the Gradation Chart is to identify the desired mix of size of aggregate in the granular base. The Target Percentage Passing is the middle of the shown Range.

Tests that show sieve values of Percent Passing that are consistently low or consistently high in two (2) or more consecutive tests will be considered to be non-conforming.

**2.11 Recycled Aggregate Material**

Delete 2.11.1 and replace with the following

Aggregates containing recycled material may be utilized if approved by the *Contract Administrator* and the City. In addition to meeting all other conditions of the specifications, recycled material should not reduce the quality of the construction achievable with quarried materials. Recycled material shall consist only of aggregates, crushed portland cement concrete, or asphalt that is free of impurities.

**END OF SECTION**

**1.4 Measurement and  
Payment**

Delete 1.4.1 and  
replace with the  
following

Payment for all clearing and grubbing will be made at lump sum price and include removal and disposal of all branches, stumps, trees, plants, debris, hedges, timbers, logs and vegetation to complete the work and as shown on the Contract Drawings or as directed by the Contract Administrator. Works include cutting of branches & falling of trees affected by Work to create the necessary clearance to accommodate the construction and intended function of the Work, and as shown on Contract Drawing. Trimming to have minimum 2.5m vertical and 0.5m horizontal clearance from sidewalk and MUP, unless otherwise directed by the Contract Administrator.

Payment includes trimming of small branches from trees or hedges as required, branch cutting/pruning to have a clean cut flush to branch collar and use of an approved tree paint to repair damage to surviving vegetation where branches have been removed.

Existing grass and top soil removal will be paid under Common Excavation, less the portion under Grubbing as defined in Clause 1.2.

**END OF SECTION**

**1.0 GENERAL**

**1.8 Limitations of Open Trench**

1.8.1  
Replace last sentence with the following

If circumstances do not permit complete backfilling of all trenches, and where permitted by the *Contract Administrator* and the City, adequately protect all open trenches or excavations with approved fencing or barricades and, where required, with flashing lights.

Add 1.8.2

The use of road plates to cover excavations and restore travel lanes is not permitted in late Fall, Winter or if forecast indicates temperature equal or below 2 degrees Celsius, unless otherwise permitted by the Contract Administrator.

Where construction necessitates the use of road plates, the Contractor is responsible for properly securing them (either pinned or recessed into the pavement) and feathered a minimum of 300mm with existing road asphalt on all four sides. The Contractor is responsible for repairing any pavement damage related to the plate installation.

**2.0 PRODUCTS**

**2.2 Use of Specified Materials**

Delete 2.2.1.2

Delete Pit Run Sand

Delete 2.2.3.3

Delete Pit Run Sand

**3.0 EXECUTION**

**3.3 Excavation**

Delete 3.3.1.2 and replace with the following

Connections to existing waterworks systems are to be made by the *Contractor* under the inspection / supervision of the *Contract Administrator* and the City.

**3.6 Surface Restoration**

Delete 3.6.2.4 and replace with the following

Restore lawns with approved topsoil and sod to match existing lawn.

Delete 3.6.3.1 and replace with the following

Restore surface with a minimum 100 mm of 19 mm granular road base material.

Delete 3.6.7.5 and replace with the following

Restore Pavement as detailed on Coquitlam Standard Detail Drawing COQ-G4. Temporary patch shall be a minimum thickness of 50 mm thickness. Permanent restoration to existing asphalt thickness (minimum of 75 mm or as shown in the Contract Drawings) with a 35 mm key where existing thickness permits. A 50 mm key is required on Arterial and Collector Roadways. Dry if necessary and paint clean, dry edge with asphalt emulsion (tack coat).

**END OF SECTION**

**1.8 Measurement and Payment**

Delete 1.8.4 and replace with the following

Payment under this item will only apply to removal of the components included in this item under a separate operation as shown on the Contract Drawings or as directed by the Contractor Administrator. No payment will be made under this item for removal of these components as part of the operation for common excavation, and such removal will be treated as common excavation.

Payment will be made at the respective unit prices bid in the Schedule of Quantities and Prices and will include all labour, and equipment required to complete the work, including offsite disposal. It is the responsibility of the contractor to locate and verify all utilities.

Delete 1.8.5 and replace with the following

Payment for Common Excavation includes:

1. Unless noted in the Schedule of Quantities and Prices as removal in square meters, common excavation will be measured in cubic meters calculated from measurements taken by the Contract Administrator in the areas of excavation for road widening areas.
2. Cross-sections will be taken after clearing and grubbing and after stripping of existing topsoil immediately prior to excavation of material to be incorporated into work.
3. Where determined by the Contract Administrator that truck box volume will be used to determine excavation quantities the volume per load shall be determined using 75% of the truck load quantity. The following is to be used for payment:

Truck Type	Material Type	Volume (cu.m)
Tandem	ordinary material	7
Tandem	asphalt/concrete/pipe	4
Triaxle	ordinary material	8
Triaxle	asphalt/concrete/pipe	5
Tandem and Pony	ordinary material	11
Tandem and Pony	asphalt/concrete/pipe	7.5
Triaxle and Pony	ordinary material	13
Triaxle and Pony	asphalt/concrete/pipe	9
Tandem and Transfer	ordinary material	19
Tandem and Transfer	asphalt/concrete/pipe	13

4. Contractor to provide truck slips detailing location type of common excavation, time loaded and location of dumpsite. The slips are to be given to Contract Administrator by the end of shift or Contract Administrator can deny quantities subsequently submitted.
5. Payment for onsite re-use includes excavation, transport, temporary stockpiling, placement, compaction, boning, adjustment of moisture content, spreading and grading of material anywhere on site or within the work zone, as needed, to establish the roadway & pathway cross-section.

Payment will be made at the respective unit prices bid in the Schedule of Quantities and Prices and will include all labour, and equipment required to complete the work, including offsite disposal.

It is the responsibility of the contractor to locate and verify all utilities.

Delete 1.8.10 and replace with the following

Payment for replacement of areas of unsuitable granular base, granular subbase or sub-grade revealed during proof rolling will include excavation with off-site disposal, installation & compaction of granular base material (25 mm minus), and all remedial work required to achieve a suitable base. Payment will be based on the cubic metre volume removed.

**2.0 PRODUCTS**

**2.2 Specified Materials**

Delete 2.2.1.3

Pit Run Sand

Delete 2.2.1.4

River Sand

Delete 2.2.2

**END OF SECTION**

COLD MILLING

1.5 Measurement and  
Payment

Delete 1.5.1 to 1.5.3  
and replace with 1.5.1  
with the following

Add 1.5.4

Payment for cold milling, under Clause 1.5.1, is incidental to work described in Section 31 24 13S, Clause 1.8.4, and includes cost of mobilization, demobilization and demonstration milling test section, unless shown otherwise in Schedule of Quantities and Prices.

Payment for this item will be made for the depth specified in the Schedule of Quantities in the Form of Tender. Payment will be made for the removal of existing asphalt, granular and native materials within the roadway to the depth specified, as detailed in the Contract Documents, in order to complete the permanent pavement restoration.

Payment will be made for each square metre of asphalt removed and includes the off-site disposal of all milled material. Payment includes mobilization, demobilization, demonstration milling test section, the cost of transport and disposal off-site, saw cutting, street sweeping or cleaning to allow for the placement of required thickness of asphaltic concrete. Saw cutting and milled key at project limits will be incidental under payment item 32 12 16 – Hot Mix Asphaltic Concrete Paving.

**MILLING OF EXTENSIVE AREAS THAT CANNOT BE PAVED WITHIN 48 HOURS PERIOD (2 DAYS) WILL NOT BE PERMITTED.**

No additional payment will be made for multiple passes or remobilization, as required, to mill to the depth(s) specified in the Schedule of Quantities in the Form of Tender.

**END OF SECTION**

GRANULAR SUBBASE

- |            |                                |   |  |
|------------|--------------------------------|---|--|
| <b>1.4</b> | <b>Measurement and Payment</b> | Delete 1.4.1 and replace with the following | Measurement for granular subbase of variable thickness will be for actual quantity placed based on weigh tickets provided to Contract Administrator as loads are delivered.  |
|            |                                | Delete 1.4.2 and replace with the following | Measurement for granular subbase for each specified thickness will be for the actual area placed.  |
|            |                                | Delete 1.4.3 and replace with the following | Payment for Subsection 1.4.1 & 1.4.2 above includes supply, placement and compaction of granular subbase material, adjustment of moisture content, and boning to establish the road cross-section, shall be included in the unit price bid in the Schedule of Quantities and Prices. |
|            |                                | Delete 1.4.4 and replace with the following | Payment for removal of unsuitable subgrade including disposal off-site prior to direct placement of granular subbase will be made under Section 31 24 13 – 1.8.10 Roadway Excavation.  |
| <b>2.0</b> | <b>PRODUCTS</b>                |   |  |
| <b>2.1</b> | <b>Specified Materials</b>     | Delete                                      | 2.1.1.1: Select Granular Subbase<br>2.1.1.2: 75 mm Pit Run Gravel<br>2.1.1.4: Pit Run Sand<br>2.1.1.5: Approved Native Material<br>2.1.1.7: River Sand   |

END OF SECTION

GRANULAR BASE

<b>1.4</b>	<b>Measurement and Payment</b>	Delete 1.4.1 and replace with the following	Measurement for granular base of variable thickness will be for actual quantity placed based on weigh tickets provided to Contract Administrator as loads are delivered.
		Delete 1.4.2 and replace with the following	Measurement for granular base for each specified thickness will be for the actual area placed.
		Delete 1.4.3 and replace with the following	Payment for Subsection 1.4.1 & 1.4.2 above includes supply, placement and compaction of granular base material, adjustment of moisture content, and boning to establish the road cross-section, shall be included in the unit price bid in the Schedule of Quantities and Prices.
		Delete 1.4.4 and replace with the following	Payment for removal of unsuitable subgrade including disposal off-site prior to direct placement of granular subbase will be made under Section 31 24 13 – 1.8.5 Common Excavation.
<b>2.0</b>	<b>PRODUCTS</b>		
<b>2.1</b>	<b>Granular Base</b>	Add 2.1.1.3	25 mm minus crushed gravel conforming to the gradation specifications for Collector/Arterial Roads under Section 31 05 17S – 2.10.3.
<b>3.0</b>	<b>EXECUTION</b>		
<b>3.5</b>	<b>Proof Rolling</b>	Delete 3.5.1 and replace with the following	For proof rolling, use fully loaded single axle, to 80 KN (18, 000 lb) minimum, dump truck.
		Add 3.5.7	<p>Prior to paving with asphalt concrete, the base surface shall be checked by the <i>Contract Administrator</i> and the City, for deflections utilizing a Benkelman Beam, in order to insure that the final rebound requirements can be obtained with the asphalt pavement. In the event that such deflection is in excess of those required to produce the final standards, then the base shall be adequately strengthened by additional gravel or asphalt concrete to insure that final deflections as follows are not exceeded.</p> <p>The Benkelman spring rebound value of the completed pavement surface shall not at any point exceed 0.75 mm for arterial industrial roads and lanes, 1.15 mm for collector roads, and 1.5 mm for local roads and lanes as determined in the procedures outlined in the Transportation Association of Canada publication “Pavement Management Guide.”</p>

END OF SECTION

ASPHALT TACK COAT

---

**1.5 Measurement and Payment**

Delete 1.5.1 and replace with the following

Payment for all work performed under this Section will be incidental to payment for work described in other Sections unless shown otherwise in the Schedule of Quantities and Prices.

Delete 1.5.2 and replace with the following

Pavement surface cleaning, as per section 32 01 11, and all other work incidental to the application of tack coat is deemed to be incidental to payment for work described in other Sections unless shown otherwise in the Schedule of Quantities and Prices.

**3.0 EXECUTION**

**3.2 Application**

Add to 3.2.3

Asphalt tack coat to be applied using a truck mounted spray bar unless otherwise approved by the *Contract Administrator* and the City. Contractor shall demonstrate, to the *Contract Administrator* and the City, prior to application that all spray nozzles are operational and providing a consistent application.

**END OF SECTION**

1.0 GENERAL

1.4 Submission of Mix Design

Delete 1.4.1 and replace with the following

Submit asphalt concrete mix design, including RAP content and trial mix test results to Contract Administrator for review at least two weeks prior to commencing work.

1.5 Measurement and Payment

Delete 1.5.1 and replace with the following

Payment for asphaltic concrete paving includes all construction joint preparation, surface cleaning and preparation, reshaping, asphaltic surface milling to tie into existing asphalt, saw cutting, supply and placing of the asphaltic concrete, compaction and cleaning frames, covers and lids of castings affected and taped temporary pavement markings.

Payment includes asphalt slot paving as shown on Contract Drawings.

Measurement for asphaltic concrete paving for the specified design mixes will be made at the respective unit prices bid in the Schedule of Quantities and Prices and incorporated into Work will be asphalt concrete actually based on weigh tickets provided to the Contract Administrator as loads are delivered.

The contractor will not receive any additional compensation above the respective unit prices bid in the Schedule of Quantities and Prices for Hand Work, Special Equipment & Machinery to complete the Hot Mix Asphaltic Paving Work as shown on the Contract Drawings or as directed by the Contract Administrator.

For measurement and payment purposes, Contract Administrator may calculate payment on actual area paved to the thickness specified in in the Schedule of Quantities and Prices and as shown on the Contract Drawings.

Delete 1.5.3 and replace with the following

Payment for asphaltic concrete sidewalks, pathways, driveways, slot paving and infill strips paving includes all construction joint preparation, surface cleaning and preparation, saw cutting, supply and placing of the asphaltic concrete, tack coat, compaction and cleaning frames, covers and lids of castings affected.

Measurement for asphaltic concrete paving for the specified design mixes for will be made at the respective unit prices bid in the Schedule of Quantities and Prices and incorporated into Work will be asphalt concrete actually based on weigh tickets provided to the Contract Administrator as loads are delivered.

Payment for this item includes all applicable materials and work described in 1.5.1. Work includes all necessary adjustments on site during construction to achieve proper tie-in to existing driveways as directed by Contract Administrator. Adjustments performed under this section shall be incidental to payment for work described in other Sections.

Add 1.5.9

The *Contractor* or the *Owner* may request adjustment of the unit prices submitted for Asphalt Pavement if the Composite Rack Posting (CRP) varies by more than 5.0% from Tender Closing Date to the time the asphalt paving is actually performed as per the schedule indicated in the Form of Tender. Neither party can make a request for unit price adjustment due to its own delay.

The CRP is a composite of the available Rack Postings for PG 64-22 FOB Langley BC.

Requests for asphalt pavement unit price adjustment must be made prior to commencing asphalt paving. Payment for asphalt paving performed prior to a request for price adjustment will be made at the unit price submitted.

Unit prices will be increased or decreased as applicable using the following formula:

$$\text{Adjustment} = (\text{CRP}_{\text{work}} - \text{CRP}_{\text{tender}}) \times \text{AC}_{\text{volume}}$$

*Adjustment* is the amount in dollars per tonne the unit price is modified.  $\text{CRP}_{\text{work}}$  is the CRP at the time paving is performed.  $\text{CRP}_{\text{tender}}$  is the CRP at the Tender Closing Date.  $\text{AC}_{\text{volume}}$  is the mixture design percent asphalt content, by volume.

1.6	<b>Inspection and Testing</b>	Add 1.6.3	Test cores will be taken by the <i>Contract Administrator</i> in the areas of new paving and will include cores along construction joints to ensure compliance with the required design and compaction.
<b>2.0 PRODUCTS</b>			
2.1	<b>Materials</b>	Add 2.1.2.1 Add 2.1.2.2	Usage of recycled asphalt shingles will not be permitted. Usage of softening agents, rejuvenators, or recycling agents will not be permitted.
2.2	<b>Mix Design</b>	Delete 2.2.2 and replace with the following  Delete 2.2.3.2 Marshall Stability and replace with the following	Mix may contain up to a maximum of 15 % by mass of RAP for Upper Course Asphalt and 20 % by mass of RAP for Lower Course Asphalt without a special mix design. The <i>Contract Administrator</i> and the City may approve higher proportion of RAP if <i>Contractor</i> demonstrates ability to produce mix meeting requirements of the specification.  Marshall Stability at 60°C for both lower and upper courses to be 10 KN min.
<b>3.0 EXECUTION</b>			
3.3	<b>Preparation</b>	Delete 3.3.3 and replace with the following	The <i>Contractor</i> is responsible for adjusting all utility manhole frames and valve boxes, belonging to Coquitlam and/or other agencies that are affected by the road works. All adjustments to utilities must be completed to the satisfaction of the utility owner. Utility adjustment within the paved surface will be considered incidental to the <i>Work</i> unless otherwise noted in the <i>Contract Documents</i> .  The <i>Contractor</i> should note that certain utility owners may decide to complete their own adjustments. The <i>Contractor</i> will be required to cooperate with any utility company providing their own adjustments.  The <i>Contractor</i> shall be responsible to contact the appropriate utility company with in minimum of seventy-two (72) hours of the work. No adjustment shall be made without the written approval of the utility company.

All manholes must be vertically adjusted a minimum of twenty-four (24) hours prior to paving. The use of riser rings for adjusting manhole frames and value boxes will not be permitted.

**3.7 Joints**

Delete 3.7.5 and  
replace with the  
following

Construct butt joints at locations as shown on the *Contract Drawing* and as directed in the field by the *Contract Administrator* and the City.

**END OF SECTION**

PAINTED PAVEMENT MARKINGS

1.0 GENERAL

1.2 Scope

Delete 1.2.1 and replace with the following

Pavement Markings: Miscellaneous taped temporary and permanent pavement paint markings including pedestrian crosswalk, merge and diverge markings, stop lines, solid and broken line road lane markings including edge lines of merge and diverge markings, bike symbols, etc. to be provided as shown on the *Contract Drawing*.

1.5 Measurement and Payment

Delete 1.5.2 and replace with the following

All permanent markings shall be marked with thermoplastic road markings as specified under Section 32 17 23S, 2.1 Materials, unless shown otherwise in the Schedule of Quantities and Prices.

Delete 1.5.3 and replace with the following

The lump sum payment for permanent thermoplastic pavement markings or MMA Solid Green covers removal of existing markings, supplying all materials and completing all the permanent thermoplastic pavement markings or MMA necessary to provide markings as shown on the Contract Drawings.

NOTE: PAYMENT FOR PERMANENT THERMPOPLASTIC PAVEMENT MARKINGS WILL NOT BE MADE UNTIL ALL TEMPORARY PAVEMENT MARKINGS AND REFLECTIVE DEVICES HAVE BEEN REMOVED.

Delete 1.5.4 and replace with the following

Payment for signage includes all sign poles, bases, sleeves, sign relocations, temporary removal, cleaning and re-installation of existing, disposal of unused materials, and sign installations (complete). The City will supply signs to supplement existing signs as required. Payment includes all labor, materials and incidentals to complete the work.

1. Installation of each new sign pole, cap, sleeve and trapezoidal base includes all costs to supply all materials, labour and equipment and incidentals, as shown on Standard Detail Drawings SS-E11.1 & SS-E11.2, necessary to the install sign structure as shown on the Contract Drawings and as directed by the Contract Administrator.

2. Installation of each new sign pole, cap, sleeve, galvanized steel bracket for no post barrier, as per MOT Drawing # SP635-3.8.3, includes all costs to supply all materials, labour and equipment and incidentals necessary to the sign structure as shown on the Contract Drawings and as directed by the Contract Administrator.

3. The unit price payment is for each city supplied aluminum sign installed on a sign pole includes sign mount clamps & all costs to supply all materials, labour and equipment and incidentals necessary to install each sign as directed by the Contract Administrator.

4. Installation of each aluminum sign on a lamp standard pole or sign pole includes sign mount clamps and all costs to supply all materials, labour and equipment and incidentals necessary to install each sign as directed by the Contract Administrator.

5. Reuse of existing signs on a lamp standard pole or sign pole includes sign mount clamps and all costs to supply all materials, labour and equipment and incidentals necessary to install each sign as directed by the Contract Administrator

	Add 1.5.5	Payment for the removal and disposal of all existing signages that are no longer required on site, as described in contract drawings or as directed by the Contract Administrator will include removal and disposal of signs, poles, bases, and all labour and equipment to complete the work.
<b>2.0</b>	<b>PRODUCTS</b>	
<b>2.1</b>	<b>Materials</b>	
	Delete 2.1.1 and replace with the following	All permanent paint markings shall be marked with thermoplastic manufactured by LAFRENTZ Road Markings, HITEX North America (HiBrite Extrude Thermoplastic), or ENNIS-FLINT (Extruded Thermoplastic).
	Delete 2.1.6 and replace with the following	Pavement Markings:
	Delete 2.1.7 and replace with the following	Thermoplastic material
		.1 Material composition shall be at the discretion of the manufacturer subject to the approval of the Contract Administrator and the City. Each formulation shall be identified by a code number.
		.2 No retained water when tested by ASTM D-570.
		.3 Specific gravity of the supplied product shall be within 3 % of that specified for the selected formulation.
		.4 Material shall not deteriorate upon contact with deicing chemicals, gasoline, diesel fuel or grease dropped by traffic.
		.5 Material shall not break down, deteriorate, scorch or discolour, if held within the application temperature range specified by the manufacturer for a period of four hours and it must be able to be reheated from room temperature to the application temperature four (4) times without showing any of these detrimental effects.
		.6 When applied at the temperature recommended by the manufacturer and at a film thickness of 2 to 4 mm, the material shall set solid and show no tracking under traffic after elapsed times as follows:
		.1 Two (2) minutes at an air temperature of 10° C, relative humidity less than 75 %, and road surface temperature from 10° C to 20° C.
		.2 Five (5) minutes at an air temperature of 32° C, relative humidity less than 75 %, and road surface temperature from 35° C to 50° C.
		.3 The drying time under conditions intermediate between the two air temperatures shall be interpolated using a straight line model.
		.7 The quantity, type, and gradation of the component reflecting glass spheres premixed in the thermoplastic material shall be at the discretion of the manufacturer, but shall provide retro reflection levels specified below.

**3.0 EXECUTION**

**3.3 Application**

Add to 3.3.1.3

Temporary raised pavement markings (TRPMs) are to be provided on all multi-lane roadways as directed by the *Contract Administrator* and the City.

Delete 3.3.3.3 and replace with the following

Thermoplastic material shall be heated in the melter to a temperature of 382 °F.

**END OF SECTION**

**1.5 Measurement and  
Payment**

Delete 1.5.4 and  
replace with the  
following

Payment for powder coated black barrier fence includes all materials, attachment plate mounting, work, and incidentals shown on MMCD Standard Detail Drawing C14 as separate items for each type of installation, including anchors and concrete bases, as required. Measurement will be made along the surface of the ground for length of each item of fence installed.

**END OF SECTION**

1 GENERAL

1.1 SECTION INCLUDES

.1 Design, labour, Products, equipment and services necessary for irrigation work in accordance with the Contract Documents.

1.2 REFERENCES

.1 CSA B137.3, Rigid Polyvinyl Chloride (PVC) Pipe for Pressure Applications (Withdrawn, No Replacement).

.2 ASTM D1248, Standard Specification for Polyethylene Plastics Extrusion Materials for Wire and Cable.

.3 ASTM D2466, Standard Specification for Poly (Vinyl Chloride) (PVC) Plastic Pipe Fittings, Schedule 40.

.4 ASTM D3350, Standard Specification for Polyethylene Plastics Pipe and Fittings Materials.

1.3 CODES AND PERMITS

.1 All work shall be installed in accordance with the requirements of local and applicable provincial and federal regulations. Any work shown on the drawings or described in the specifications which is at variance with the regulations shall be changed to comply with the requisite authority at no cost to the City.

.2 WorkSafe BC regulations shall be followed.

.3 The Subcontractor shall be responsible for obtaining all permits and licenses required to undertake and complete the work. Include costs for required permits and approvals in tendered prices.

.4 Provide the Consultant with signed and approved copies of all required permits, including the following:

- .1 Backflow test report.
- .2 Technical Safety BC Electrical Contractor Authorization and Declaration of Compliance Electrical Inspection Request Form.

1.4 SUBMITTALS

.1 Provide a Certified Irrigation Contractor certificate and proof of good standing with the Irrigation Industry Association of BC or the Irrigation Association within 5 days of receipt of the Notice to Proceed.

.2 Provide FSR C R Low Energy field safety representative certificate of qualification and Electrical Contractor License within 5 days of receipt of Notice to Proceed.

.3 Provide Backflow Assembly tester certificate within 5 days of receipt of Notice to Proceed.

.4 If required, the Subcontractor shall submit evidence of project personnel having certification in High-Density Polyethylene Butt Fusion within 5 days of the Notice to Proceed.

.5 The Subcontractor shall submit Shop Drawings for approval by the Consultant prior to construction. Shop Drawings of the irrigation system are required for all aspects of the irrigation system not included in the Drawings. This includes but is not limited to:

- .1 Revisions to irrigation system design not previously addressed in Contract Documents, including revisions to irrigation system design which markedly alter the original design, as determined by the Consultant.
- .2 Installation details for irrigation components are not addressed in the Contract Documents.
- .3 Details are required by the consultant for the review of proposed substitutes.
- .4 Tasks identified in project specifications as requiring a Shop Drawing.
- .5 Submit shop drawings to the consultant for review, comment, approval, or rejection.

- .6 The Subcontractor shall submit product literature for approval by the Consultant prior to the start of construction.
- .7 Provide Electrical Installation Permit and Electrical Contractor Authorization and Declaration of Compliance Electrical Inspection Request upon permit issuance.
- .8 Submit a complete set of Record Drawings to the Consultant prior to the issuance of a Certificate of Substantial Performance. Submit a digital copy in .pdf and .dwg format, hard copies in full and half-sized, and a half-sized laminated copy in the controller cabinet.
- .9 Submit the complete Operating Manual to the Consultant prior to issuance of Substantial Performance. Provide one (1) hard copy in a binder and one (1) digital copy.
- .10 Submit a written guarantee to the Consultant prior to issuance of Substantial Performance.

#### 1.5 IRRIGATION RECORD DRAWINGS

.1 Maintain accurate scaled records of the installed irrigation system and its components on a marked-up set of Contract Documents daily during Construction. Show all deviations from the Contract Drawings. Make marked-up Contract Drawings available to the Consultant upon request.

.2 For sports fields and large parks, retain a qualified survey instrument operator to record the exact locations of all installed irrigation components, including changes of pipe direction.

.3 The Record Drawings shall be submitted within 14 days of issuance of Substantial Performance. Submit one (1) full-sized copy, one (1) half-sized copy, and one (1) half-sized laminated copy. Submit digital copies in .pdf and .dwg format with the digital submission of the Operating Manual.

.4 The Record Drawings must clearly and legibly show all components of the irrigation system as installed, including wire splices. The Record Drawings must include the following:

- .1 Identify each zone numerically, complete with precipitation rate and GPMs per zone.
- .2 Scale and north arrow.
- .3 Legend of all equipment installed, complete with make and model of each product.
- .4 Date of installation.
- .5 Irrigation watering schedule.
- .5 The Subcontractor shall maintain the as-built record drawing throughout the maintenance and warranty period and issue a revised as-built Irrigation Drawing at Final Acceptance if any changes are made. The as-built drawings shall be certified by the landscaping subcontractor as being an accurate record of the installation.

#### 1.6 OPERATING MANUAL

.1 Prepare a complete Operating Manual for the installed irrigation system. The Operating Manual shall be submitted within 14 days of issuance of Substantial Completion. The content of the Operating Manual must include:

- .1 Product literature and warranty documentation
- .2 Equipment operating instructions.
- .3 Maintenance instructions, including spring start-up and winterization procedures.
- .4 Copies of all irrigation inspection reports and test results.
- .5 Copies of the backflow test report and Electrical Permit.

.2 A written guarantee statement covering workmanship and materials shall be provided to the City for at least one (1) year from the date of Substantial Performance. The Subcontractor shall warranty maintenance on the system for at least one (1) year, including but not limited to spring start-up, adjustments and maintenance operations as required, and winterization. The Subcontractor will also attend a warranty inspection before handover.

#### 1.7 QUALITY ASSURANCE

.1 The Subcontractor performing this work shall be a "Certified Irrigation Contractor," having met the certification standards established by the Irrigation Industry Association of British Columbia or the Irrigation Association and having experienced, trained, and insured personnel qualified for the scope of work.

.2 Be certified as a Class C R Low Energy field safety representative (FSR) registered with Technical Safety BC as an Electrical Contractor.

.3 If the design involves High-Density Polyethylene Pipe (HDPE), the Subcontractor shall be certified in High-Density Polyethylene Butt Fusion as certified by the British Columbia Institute of Technology or approved equivalent.

.4 Manufactured products, including but not limited to irrigation heads, quick couplers, controllers, valve boxes and valves, will be warranted as per the manufacturer's standard warranty period or a minimum of one (1) year, whichever is greater.

.5 The double-check valve assembly and meter shall be installed and tested by a certified and licensed backflow tester with B.C.W.W.A.

.6 All electrical components or products specified or used in the construction of the proposed irrigation system must be CSA-approved and installed in accordance with all local, provincial, and national electrical codes.

.7 All materials are to be new and without flaws.

.8 The completed irrigation system is to efficiently and uniformly irrigate all areas and perform as required by these specifications.

.9 A written guarantee of the installed irrigation system shall be provided to the City covering workmanship and materials for at least one (1) year from the date of substantial completion. The Subcontractor shall warranty maintenance on the system for at least one (1) year, including but not limited to spring start-up, adjustments and maintenance operations as required, and winterization.

#### 1.8 TESTS AND INSPECTIONS

.1 Inspection and testing of components will be required at various milestones during construction to ensure the irrigation system's performance meets expected standards.

.2 Provide equipment and personnel necessary for the performance of inspections and tests.

.3 The Subcontractor shall provide a minimum of 3 days' notice to the Consultant of required inspections.

.4 Conduct all inspections and tests in the presence of the Consultant and request the Consultant issue a signed report to the Subcontractor within three days regarding each test result.

.5 Keep work uncovered and accessible until successful completion of inspection or test.

.6 As a condition of issuance of a Certificate of Substantial Performance, confirm in writing to the Consultant the following inspections and successful tests:

- .1 Backflow prevention test.
- .2 Point of Connection Inspection.
- .3 Mainline Inspection.
- .4 Mainline pressure test.
- .5 Mainline pressure test.
- .6 HDPE pipe strap test.

.7 System installation inspections shall be held regularly.

.8 Backflow Assembly Test:

- .1 Conduct backflow prevention assembly test as per BC Water Works Association standards using qualified personnel.
- .2 Conduct backflow upon backflow assembly installation and submit the report to the Consultant.

.9 POC Inspection:

- .1 Inspect the point of connection. Inspect all components, connections, wire splices, supports, and sizing.
- .2 Call for inspection upon completing the installation of the point of connection.
  
- .10 Mainline Inspection:
  - .1 Inspect the mainline trench, depth, sand bedding, welds, connections, caution tape, and wire.
  - .2 Call for inspection once 50% of the mainline is installed.
  
- .11 Mainline Pressure Test:
  - .1 Perform mainline pressure test to identify potential leaks and ensure mainline can operate at design pressure and maintain pressure.
  - .2 Conduct mainline pressure test before backfilling of mainline.
  - .3 Fill the mainline with water and expel all air from the pipe. Maintain water in the pipe for 3 hours.
  - .4 Subject mainline to hydrostatic pressure of 120psi or twice the optimum design pressure of the mainline and not to exceed 160psi.
  - .5 Stop the make-up water supply from going to the mainline and record hydrostatic pressure.
  - .6 Visually inspect mainline and fittings for leaks.
  - .7 Record hydrostatic pressure in the mainline 3 hours after the supply of make-up water stopped.
  - .8 The test result is determined based on the difference in recorded pressures at the beginning and end of the test. A 5% difference or less is considered a pass.
  - .9 Identify the source of the leak and replace all defective material and workmanship as necessary to eliminate the leak.
  - .10 Repeat the mainline pressure test and make replacements as necessary until a passed result is achieved.
  
- .12 System Coverage and Operation Test:
  - .1 Conduct coverage and operation tests after installation and operation of the complete irrigation system. Conduct inspection to confirm that:
    - .1 Head spacing does not exceed the distances shown on Contract Drawings, and head-to-head coverage is achieved.
    - .2 Where applicable, irrigation piping should be installed to follow the contours of the land to minimize low-head drainage situations.
    - .3 Heads, boxes, vaults, and trenches are at a specified elevation relevant to the finished grade and are not subject to settlement or lifting.
    - .4 Valves are installed with the required clearances, materials, products, and connections.
    - .5 All irrigation components are installed with all required clearances, materials, products, and connections.
  - .2 Conduct operational tests to verify that:
    - .1 The controller can be programmed manually and remotely via the City's central control system.
    - .2 The controller can send and receive communication with the City's central control system 10 consecutive times without a missed communication.
    - .3 The controller responds to the flow sensor.
    - .4 Operating pressure is within design parameters.
    - .5 Each zone can be operated automatically and in succession via the programmed controller.
    - .6 There is no overspray onto different control zones, hard surfaces, or other improvements.
  
- .13 Dripline Emitter Test:
  - .1 Perform inspection and testing of the dripline/emitter manifold and lines to identify potential leaks and confirm that the manifold, driplines, and emitters can operate at design pressure. Conduct inspection and testing prior to backfilling the manifold, driplines, or emitters.
  - .2 Fill the manifold and lines with water at operating pressure and maintain pressure for 15 minutes. Visually inspect the manifold, driplines, and fittings for leaks. Confirm that emitters are functioning correctly. Identify sources of leaks and replace all defective materials and workmanship as necessary to eliminate the leak.
  - .3 Repeat inspection and testing and make replacements as necessary until no further leaks are identified.
  
- .14 HDPE Pipe Strap Test:
  - .1 Conduct an HDPE pipe strap test at least 1 hour after the fusion weld has been made before backfilling of HDPE pipe on those fusion welds where, upon visual or tactile inspection, the bead does not roll back properly or is inconsistent in height or width.
  - .2 HDPE pipe strap consists of:

- .1 Cut fusion weld from pipe, allowing 200mm on either side of weld to work with.
- .2 Cut pipe lengthways through fusion weld to create a strap 25mm wide.
  
- .3 Bend strap back on itself.
- .4 If weld breaks repeat test on another fusion weld, chosen by the Consultant. If second fusion weld fails, then all welds become suspect, and the HDPE pipe cannot be installed until the reason for the fusion joint failures is determined.
- .5 If the fusion weld does not break, then the weld is acceptable, and no further testing of similar welds is required.
- .6 Replace or repair the tested pipe strap.
  
- .15 Vault Drainage Test:
  - .1 Conduct vault drainage test when the vault is installed and backfilled.
  - .2 Plug the drain, fill the vault with water to a depth of 300mm, and leave the water to drain.
  - .3 Determine the test result based on the time required for the water to drain. To pass this test, the water must drain in 60 minutes or less.

#### 1.9 SUBSTITUTIONS

- .1 Where materials are specified by brand name and model number, such specifications shall be deemed to facilitate a description of the materials and material quality and shall establish a standard for performance and quality against which proposed substitutes shall be evaluated.
- .2 Substitution requests shall not be considered unless submitted in writing with sufficient descriptive literature and product samples to permit product comparison.
- .3 All product substitutions shall be equal to or greater than the original design in performance, value, and water efficiency. All proposed sprinkler substitutions must be accompanied by verifiable water efficiency performance data provided by the manufacturer or an independent industry source such as the Centre for Irrigation Technology (CIT), Fresno.
- .4 Alternate materials shall match the specified materials in performance, flow, and pressure loss so as not to compromise the intent of the design.
- .5 The consultant's written approval is required for the use of materials different from those shown in the design. Materials installed that have not been preapproved by the Consultant are subject to removal and replacement with approved materials at the Subcontractor's expense.
- .6 Substitution requests by the Subcontractor shall have no impact on Milestone Dates.

#### 1.10 SITE CONDITIONS

- .1 Verify the existence and location of all underground utilities and services before the commencement of the work.
- .2 Consult with the Consultant to adjust the design, if necessary, to suit existing site conditions and grades before the work commences.
- .3 Ensure that sequencing of irrigation work is carried out in coordination with the work of other trades and that sleeves, wire, pipes, valves, and other equipment are installed when appropriate.
- .4 Plan, schedule and execute work to ensure a water supply is available for landscape establishment and maintenance purposes at the appropriate time, in adequate amounts, and operating at design pressures to ensure satisfactory irrigation of all landscaped areas.
- .5 Report to the Consultant in writing any conditions or defects encountered on the site during or before construction upon which the work of this section depends and which may adversely affect its performance.

.6 Protect existing landscape features, plant material, structures, irrigation work in progress, and the work of other trades from damage.

#### 1.11 MEASUREMENT AND PAYMENT

Payment will include cost for removal of irrigation heads, adjustment to irrigation lines, sleeving of lines coming under hard surfaces, cutting and capping complete as required.

Payment will also include coordination by Contractor for all irrigation modifications required for the cross walk, including but not limited to:

- Removal and disposal of existing irrigation heads, swing joints, lateral lines, control wiring, valve boxes, and associated components within the limits of construction.
- Relocation and adjustment of irrigation heads and lateral lines, as required to suit the revised layout and maintain full irrigation coverage to adjacent landscaped areas.
- Relcoation of water service meter box
- Protection of existing irrigation infrastructure intended to remain.
- Maintain continuity and operability of the existing irrigation system at all times where practical.
- Repair any irrigation components damaged during construction at no additional cost to the City of Coquitlam.
- Cap abandoned lateral lines and wiring in waterproof valve boxes where applicable.
- Provide new wire splices using waterproof irrigation connectors only.
- Adjust irrigation head spacing and nozzle selection as required to prevent overspray onto new paving surfaces and road.
- Verification that no dead zones are created after removal of the end heads
- Flush and test all modified irrigation zones upon completion of work.
- Confirm proper operation, coverage, and controller communication for all affected stations prior to project closeout.
- As-built drawings shall reflect all irrigation modifications.
- Any irrigation shutdowns shall be coordinated with the City of Coquitlam to avoid impacts to landscape maintenance and plant health.
- The Contractor shall ensure that all landscaped areas outside the paving limits continue to receive adequate irrigation coverage following completion of the work.

## 2 PRODUCTS

### 2.1 ELECTRICAL PRODUCTS

.1 All electrical products shall be CSA-approved and bear the CSA label. Alternatively, where a product does not bear the required CSA label, it shall be approved in writing by the authority having jurisdiction.

.2 The wiring conduit shall be a Grey PVC DB2 non-metallic electric conduit, as shown on the drawings, with a minimum diameter of 50 mm.

### 2.2 ELECTRICAL SERVICE AND METER

.1 Unless already installed or otherwise required by the electrical utility having jurisdiction over the site, provide a metered electrical service, including but not limited to:

- .1 Electrical permit.
- .2 Electrical meter.
- .3 Establish and verify the electrical account with the appropriate utility provider.

.2 The type and size of electrical service are to be specified in the contract drawings.

.3 Unless specified otherwise, an electric meter is to be supplied and installed according to the electrical utility's standards and specifications.

## 2.3 IRRIGATION CONTROLLER

.1 Acceptable controllers are the Toro DXi Central Control Assemblies series. Refer to the design for specific models.

.2 The controller must include a Toro M8C cellular Kit with an antenna.

.3 Where power is not available, acceptable battery-operated controllers are:

- .1 Rain Bird ESP-BAT-BT
- .2 Toro Tempus DC Series

## 2.4 CONTROLLER CABINET

.1 Acceptable controller cabinets include the following:

- .1 DXi Stainless Steel Wall Mount Cabinet.
- .2 DXi Stainless Steel Pedestal Type 1.
- .3 Or as shown on the Contract Drawings.

## 2.5 CONTROL WIRE

.1 The control wire from the irrigation controller to the electric control valve is to be a minimum of #14 gauge, with direct burial and type TWU 40 wire. It may be any colour other than white, blue, purple, or red.

.2 The common wire from the irrigation controller to the electric control valve must be a minimum #14 gauge direct burial, type TWU 40 wire, and white in colour.

.3 The master valve wire from the controller to the valve must be a minimum #14 gauge direct burial, type TWU 40 wire, and it must be red in colour.

.4 The spare control wire is to be blue in colour.

.5 Spare common wire to be white in colour.

.6 All connectors will be new, two-step, CSA-approved for watertight applications and assembled according to the manufacturer's recommendations.

## 2.6 TWO-WIRE CONDUCTOR

.1 The Paige Electric P7350D shall be used to communicate between the controller and the field decoders at the electric control valves.

.2 Single conductor spare decoder wire shall be CSA-approved #14 AWG Blue.

.3 All control wires installed shall use a Polyethylene outer jacket.

.4 All connectors are to be new, two-step, CSA-approved for watertight applications and assembled according to the manufacturer's recommendations.

## 2.7 GROUNDING AND BONDING

.1 Ground assembly consists of CSA and BC Electrical Code-endorsed products per the irrigation controller manufacturer's recommendations for grounding.

## 2.8 WIRE SPLICE BOXES

These Supplementary Contract Specifications must be read in conjunction with the Specifications contained in the Master Municipal Construction Documents, Volume II, Printed 2009 and the City of Coquitlam Supplementary Specifications and Detailed Drawings

.1 The wire splice box, matching lid, and extensions are to be commercial grade and grey in colour. The wire splice box is to have a locking overlapping lid with a stainless steel bolt locking device and appropriate washers.

## 2.9 WATER SERVICE AND METER

.1 Unless already installed or otherwise required by the water utility having jurisdiction over the site, provide a metered water service, including but not limited to:

- .1 Permit.
- .2 Backflow prevention assembly.
- .3 Establish and verify water accounts with the appropriate utility provider.

.2 Supply and install a water meter in accordance with the requirements of the water utility.

.3 Conform water meter size to mainline diameter and allow for minimal pressure losses.

## 2.10 VAULT AND LID

.1 Refer to Contract Drawings for acceptable vaults and lids for point-of-connection components.

.2 Lids to have recessed hinges and locking hardware.

## 2.11 VAULT DRAIN

.1 Perforated Schedule 40 PVC pipe, 100mm diameter with threaded inlet cover having 13mm grated openings.

## 2.12 BACKFLOW PREVENTION ASSEMBLY

.1 Acceptable double-check valve assemblies are:

- .1 Watts Series 007 Double Check Valve Assembly.
- .2 Apollo 4A 100 Double Check Valve Assembly.

## 2.13 FLOW SENSORS

.1 Flow sensors are to be PVC, sized to match system low and high flows. Acceptable flow sensors are:

- .1 Toro TFS 050.
- .2 Toro TFS 075.
- .3 Toro TFS 100.
- .4 Toro TFS 150.
- .5 Toro TFS 200.
- .6 Toro TFS 300.
- .7 Toro TFS 400.

.2 Acceptable wires for the flow sensor shall be shielded, direct burial communication cable and include the following:

- .1 Regency Wire PE 39 Communication Cable.
- .2 Paige Electric P71R2D.
- .3 Approved equal.

## 2.14 MASTER VALVE

.1 Acceptable master valves are as follows:

- .1 Rain Bird PEB Series.
- .2 Toro P220 Series.

.2 Master valve to be sized to maximum and minimum flow parameters as shown on Contract Drawings.

## 2.15 PRESSURE REDUCING VALVE

.1 Acceptable water pressure-reducing valves are Watts Series 25AUB Z3.

**2.16 BLOW-OUT ASSEMBLY**

.1 Blowout assembly to consist of a tee with a 25 mm ball valve with a plug.

**2.17 QUICK-COUPLING VALVE**

.1 Acceptable quick coupling valves are as follows:

- .1 19mm Rain Bird 3 RC.
- .2 25mm Rain Bird 5 RC.

**2.18 GATE VALVE**

.1 For gate valves sized up to 50mm, acceptable gate valves include the following:

- .1 Red White #280.
- .2 Toyo #206A.

.2 Acceptable gate valves that are sized greater than 50 mm are as shown on Contract Drawings.

**2.19 POLYVINYL CHLORIDE (PVC) PIPE**

.1 Conform to CSA B137.3.

.2 New condition, extruded from virgin, high impact materials, solvent weldable with belled ends, continually and permanently marked showing manufacturer's name, material, size, and pressure rating.

.3 Acceptable PVC pipe to be as follows:

- .1 Class 200 PVC.
- .2 Schedule 40 PVC.

**2.20 POLYETHYLENE (PE) PIPE**

.1 New condition Series 100, in new condition, extruded from virgin materials, continually and permanently marked showing manufacturer name, material, size, and pressure rating.

**2.21 HIGH DENSITY POLYETHYLENE (HDPE) PIPE**

.1 New condition CSA Approved, extruded from virgin materials, continually and permanently marked showing manufacturer's name, materials, size, and pressure rating.

.2 Material to be listed by the Canadian Standards Association (CSA) and Plastic Pipe Institute (PPI) as a PE 3408 resin with a hydrostatic design basis (HDB) of 1600 psi for water at 231C. Material to comply with ASTM D1248 as a Type III Class C, Category 5, Grade P34 material and with ASTM D3350 as a 345434C cell material.

.3 Acceptable HDPE pipe is dependent on operating pressure and to have Standard Density Ratios (SDR) as follows:

- .1 Max. pressure up to 100psi: SDR 17.0.
- .2 Max. pressure exceeding 100psi: SDR 11.0.

**2.22 SLEEVING**

.1 Schedule 40 PVC for irrigation sleeve in a bored hole or under the hard surface.

.2 Irrigation sleeve diameter is to be a minimum of 50mm or twice the diameter of the pipe running through it, whichever is greater.

.3 Control wire conduit to be a minimum of 50mm diameter CSA Approved electrical conduit.

2.23 FITTINGS

- .1 New condition Schedule 40 PVC is conforming to ASTM D2466 standards and is of the same material as the pipe. Fittings are to be designed for solvent welding to PVC pipe except where valves and risers require threaded joints.
- .2 Nipples are to be threaded Schedule 80 PVC and manufactured from the same material as pipe.
- .3 At the point where the supply source changes from metal to PVC pipe, the metal end of the pipe must be an FIPT (female) adapter and the PVC fitting a MIPT (male) adapter.
- .4 Flange couplers may be used upon approval of the Consultant.
- .5 The fittings for the LDPE pipe are to be Spears insert fittings complete with stainless steel gear clamps.
- .6 Fittings for HDPE pipe to be butt fusion type for end-to-end joints.
- .7 The SDR rating of HDPE fittings must match the SDR rating of the HDPE pipe specified.
- .8 HDPE pipe fittings are to be moulded or fabricated by the pipe manufacturer. HDPE pipe fittings and flange adapters made by contractors or distributors are prohibited.
- .9 Fittings for dripline and drip emitters to be compatible with specified dripline or emitter and as recommended by the manufacturer.
- .10 All pipes and fittings installed in the irrigation vault are to be Schedule 80 per Drawings.

2.24 PIPE SOLVENT AND PRIMER

- .1 PVC pipe solvent and primer combinations are recommended by the manufacturer and suitable for use with specified materials and applications.
- .2 Use solvent and primer as directed by the manufacturer. Use only solvent and primer that meets local codes.
- .3 The use of wet and dry solvents and primers is prohibited.

2.25 VALVE BOXES

- .1 Acceptable irrigation valve boxes are:
  - .1 Rain Bird VB Series Valve Boxes.
  - .2 NDS Pro-Spec Series.
- .2 Valve box and matching T Cover Lid and extensions to be commercial grade and green in colour.
- .3 The valve box is to have a locking lid with a stainless steel bolt locking device and appropriate washers.

2.26 ELECTRICAL CONTROL VALVE

- .1 Acceptable electric control valves are:
  - .1 Rain Bird PEB Series.
  - .2 Toro P 220 Series.
- .2 Size the electric control valve in accordance with the valve manufacturer's recommendations for the design flow.

2.27 SWING JOINT ASSEMBLY

- .1 Acceptable swing joint assemblies for sprinklers flowing up to 8 gpm:

.1 Rain Bird SA Series Swing Assembly.

.2 For sprinklers flowing greater than 8gpm, use swing joints with three (3) threaded Schedule 40 PVC elbows and one threaded Schedule 80 PVC nipple.

.3 The length of the nipple shall be such a length to permit the installed head or valve to be set as specified.

.4 The diameter of the nipple to match the inlet for the valve or head is shown on the Contract Drawings.

#### 2.28 SPRINKLERS - SPRAYHEADS

.1 Acceptable sprayhead sprinklers are as follows:

- .1 Rain Bird 1806 SAM-PRS, 1806 SAM P45, 1812-SAM-PRS, 1812-SAM-P45 Series.
- .2 Rain Bird RD1800 Series Spray Heads.

.2 Acceptable nozzles are Rain Bird MPR fixed arc nozzles. Where fixed arc nozzles do not fit the desired irrigated area, use Rain Bird HE VANS.

#### 2.29 SPRINKLERS - ROTORS

.1 Acceptable rotors are as follows:

- .1 Rain Bird 5004 + SAM R Series.
- .2 Rain Bird Falcon 6504 Series.
- .3 Rain Bird 8005-SS Series for sports field applications.
- .4 Rain Bird 8005.

#### 2.30 ROOT WATERING SYSTEM

.1 Acceptable root watering systems are Rain Bird RWS Series, and the size and depth are specified on the contract drawings.

.2 Root watering systems shall be outfitted with a Rain Bird RWS SOCK when installed.

#### 2.31 DRIP ZONE KITS

.1 Acceptable drip zone kits are as follows:

- .1 0.3 to 20 GPM: Rain Bird XCZ 100 PRB COM.
- .2 15 to 40 GPM: Rain Bird XCZ 150 LCS.

#### 2.32 FILTERS

.1 Acceptable filters are as shown on the Contract Drawings.

.2 Filter to be commercial grade appropriate for designed flow rates and manufactured by Rain Bird.

#### 2.33 LANDSCAPE DRIPLINE

.1 Acceptable driplines are as follows:

- .1 Rain Bird XFD On Surface Dripline.
- .2 Rain Bird XFS Sub Surface Dripline.
- .3 Rain Bird XFS CV Dripline.

#### 2.34 DRIP EMITTERS

.1 Acceptable emitters are Rain Bird Xeri bugs, sized as shown on Contract Drawing.

#### 2.35 LATERAL FLUSH ASSEMBLY

These Supplementary Contract Specifications must be read in conjunction with the Specifications contained in the Master Municipal Construction Documents, Volume II, Printed 2009 and the City of Coquitlam Supplementary Specifications and Detailed Drawings

.1 Ball valve with a street elbow on swing joint assembly complete with Rain Bird VB10RND valve box.

2.36 AIR RELIEF VALVES

.1 Acceptable air relief valves are Rain Bird ARV050 Air/Vacuum relief valves.

2.37 THRUST BLOCK

.1 Thrust blocks to be 20MPa at 28-day strength. Thrust blocks can be either:

- .1 Poured in place concrete.
- .2 Pre-cast concrete block.

2.38 BACKFILL MATERIAL

.1 Native excavated material shall be clean excavated soil, free from organic matter, stones larger than 25mm, building debris, and other foreign substances.

.2 Sand: pit run sand.

3 EXECUTION

3.1 EXAMINATION

.1 Report existing conditions at variance with Contract Drawings to the Consultant.

.2 Verify locations of underground utilities before commencing excavation and conduct work to prevent interruption and damage to services and utilities. Make good all damages to same at Subcontractor's cost.

.3 Verify the location of all services in building walls before boring or drilling holes. Make good all damages to same at Subcontractor's cost.

.4 Protect existing conditions and complete work from disturbance during work. Make good all damages to same at Subcontractor's cost.

.5 Adjustments to the irrigation system installation to avoid existing conditions, completed work, and utilities will be permitted subject to prior approval by the Consultant.

3.2 LAYOUT

.1 Locations of irrigation components shown on plans are schematic in nature. Coordinate the actual location of irrigation components with landscaping, building and physical features of the site. Confirm proposed changes to the location of irrigation components in writing with the Consultant before installation. Changes that markedly alter the irrigation design, in the consultant's opinion, require the submission of Shop Drawings and an updated Design Report to the Consultant for their permission to proceed. Record all approved revisions on a marked-up set of Contract Drawings.

.2 Layout and stake irrigation system per Contract Drawings to confirm:

- .1 The layout is within the project boundary and property lines.
- .2 Site grades are consistent with Contract Drawings.
- .3 Damage to the root system of existing trees is minimized.
- .4 Installation of irrigation components to be a minimum of 1 meter outside the dripline of existing trees.
- .5 Minimum horizontal and vertical clearances from electrical and other utilities are met.
- .6 Location of all sleeving, mainlines, pedestals, vaults, valve boxes, and splice boxes.

3.3 EXCAVATION

.1 Excavate to ensure depth and bedding requirements are met.

.2 All excavation is unclassified. Report any material or site condition that cannot be excavated by normal mechanical or normal means, or that may affect excavation to the required depth to the Consultant before excavation.

.3 Identify and recycle all suitable materials recovered during construction.

.4 Remove and dispose of buried debris exposed during excavation, including decommissioned irrigation materials and underground utilities, which may impede the proper installation and operation of the irrigation system.

### 3.4 IRRIGATION CONTROLLER

.1 Install irrigation controller in the cabinet as per Contract Drawings.

.2 Coordinate controller installation with other electrical components.

.3 Install controller and wiring in accordance with local, provincial, and national electrical codes.

.4 Install communication components per the manufacturer's recommendations and establish communication between the controller and the City's Central Control System, including relays or boosters as necessary.

.5 Before issuance of Certificate of Substantial Performance, request irrigation program from the Consultant and set controller program accordingly.

### 3.5 CONTROLLER CABINET

.1 Install the controller cabinet in the location shown on Contract Drawings or in an alternate location approved or directed by the Consultant.

.2 Orient alignment of the controller cabinet as approved by the Consultant, to provide optimal observation of the irrigation system in operation.

.3 Install the controller cabinet using a poured-in-place concrete pad mount.

.4 Provide electrical service to controller cabinet as shown in Contract Drawings.

### 3.6 CONTROL WIRE

.1 Install control wire per code by qualified personnel employed by the company holding the electrical permit.

.2 Bury control wire per applicable code and in no case above the bottom side of the parallel pipe.

.3 Bed control wire in sand with a minimum of 50 mm sand around the control wire. Where the control wire is in the same trench as the pipe, place the wire beside the pipe with a horizontal clearance of a minimum of 50 mm and in accordance with BC Electrical Code depth.

.4 Bundle multiple lengths of wire in the same trench or conduit with ties at a maximum of 3.0m intervals.

.5 Install wire with 600 mm length of coiled slack at all direction changes, in wire splice boxes and at connections to controlled components.

.6 Identify all control wires entering the controller cabinet with a permanent label or tag indicating the zone number of the valve operated by each control wire.

.7 Maintain consistent wire colour through wire splice box.

.8 Minimize wire splices. Where wire splices are unavoidable, make splices only in the wire splice box using a specified connector.

.9 Identify spliced wire with permanent label or tag indicating zone number of the spliced control valve.

.10 Where specified on Contract Drawings, install extra control wire to wire splice box. Provide 600 mm of coiled slack of each wire end in the wire splice box. Identify extra control wire as 'extra' wire with a permanent label or tag.

### 3.7 GROUNDING AND BONDING

.1 Install ground assembly in the location shown on Contract Drawings or the revised location approved by the Consultant.

.2 Use the rod, plate and wire configuration as recommended by the manufacturer of the irrigation controller and per BC Electrical Code.

### 3.8 WIRE SPLICE BOX

.1 Where possible, locate the wire splice box in the planting bed for ease of access, maintenance, and testing.

.2 Install the wire splice box per the drawings and arrange it neatly and in an orderly manner.

.3 Do not install valves in the wire splice box.

.4 The wire splice box is to be a Rain Bird VB10RND valve box.

### 3.9 WATER SERVICE AND ACCOUNT

.1 Establish a water utility account and obtain permits and approvals necessary to install and operate irrigation systems.

.2 Review regulations and restrictions imposed by applicable water utility with a Certified Irrigation Designer and advise the Consultant of any regulations or restrictions that will affect the operation of the proposed irrigation system. Provide the Consultant with the options necessary to respond to any regulations or restrictions affecting the operation of the proposed irrigation system.

.3 Coordinate with water utility as required to confirm availability, suitability, and location of an acceptable service connection.

.4 Isolate water service before installation of any irrigation components.

.5 Install water service to the point of connection. Refer to City requirements for irrigation water service.

### 3.10 VAULT AND LID

.1 Install vault in location on Contract Drawings or in an alternate location approved or directed by the Consultant.

.2 Support and brace point of connection components, piping and valves within the vault using adjustable aluminum pipe stands complete with riser, pipe clamps, base plate, and stainless steel fittings in the quantity per service size indicated as follows:

- .1 19 mm: 2 supports.
- .2 50 mm: 3 supports.
- .3 64 mm and greater: 3 supports per vault.

.3 Use Schedule 80 Pipe and fittings for inside vault and extend outside the vault a minimum of 300mm beyond the vault.

.4 Connect PVC and metal pipes using male threads on PVC and female threads on metal pipes.

.5 Install vault drain and connect to drain pit, dry well, manhole or catch basin.

**3.11 VAULT DRAIN**

.1 The vault drain consists of a minimum of 2m<sup>3</sup> of 25mm drain rock wrapped in landscape fabric.

.2 The pipe from the vault shall have a minimum of 0.5% slope from the vault to the drain pit.

**3.12 BACKFLOW PREVENTION DEVICE**

.1 Install the Double Check Valve Assembly (DCVA) in a lockable concrete vault or a locked mechanical room, per the Contract Drawings.

.2 Install the backflow prevention assembly in accordance with all applicable codes and bylaws and the current Cross Connection Control Manual Accepted Procedure and Practice (BCWWA).

.3 Support backflow prevention assembly with specified supports per the manufacturer's recommendations for locations of the support points.

**3.13 FLOW SENSOR**

.1 Install flow sensor in the location specified by Drawings.

.2 The flow sensor wire is to run continuously, with no splices, between the flow sensor and irrigation controller.

.3 There must be an unrestricted pipe for at least 10x the pipe's diameter upstream and 5x the pipe's diameter downstream of the tee.

.4 Follow the manufacturer's recommendations for the installation of a flow sensor and wiring.

**3.14 MASTER VALVE**

.1 Install master valve per Contract Drawings.

**3.15 PRESSURE REDUCING VALVE**

.1 Install a pressure-reducing valve as shown on Contract Drawings.

**3.16 BLOW-OUT ASSEMBLY**

.1 Install the blow-out assembly immediately in a vault at the point of connection. If the point of connection is inside a building, install the blow-out connection immediately downstream of the isolation valve where the mainline pipe exits the building.

**3.17 QUICK COUPLERS**

.1 Install in valve box per manufacturer's recommendations and Contract Drawings.

**3.18 GATE VALVE**

.1 Install in valve box per manufacturer's recommendations and Contract Drawings.

.2 Where points of connections are located within a building, install an isolation valve immediately downstream of where the pipe exits the building, in a rectangular valve box.

3.19 PIPES AND FITTINGS

- .1 Verify that all pipes, fittings, primer, and cement are compatible for proper installation.
- .2 Do not locate the open side of the trench any closer than 300 mm from the hard surface or feature.
- .3 Keep the inside and outside of the pipe and its ends clean at all times. Cap or plug open pipe ends to keep out dirt and debris.
- .4 Cut PVC pipe ends at a right angle to pipe length, and clean burrs before joining pipe and fittings.
- .5 Immediately before joining pipe and fittings, wipe contact surfaces clean with primer.
- .6 Apply a light coat pipe of cement on the inside of the fitting and a heavier coat on the outside of the pipe. Insert the pipe into the fitting and give a quarter turn to seat cement. Wipe excess cement from outside of the pipe.
- .7 Consultant reserves the right to request that the Contract remove and replace any solvent weld joints that are
- .8 Wrap male threads of threaded fittings with a minimum of 3 wraps of Teflon tape immediately prior to making a connection.
- .9 Flush all irrigation pipes fully to remove accumulation of dirt and debris before installation of heads, dripline, emitters, and filters. Flush all laterals in a manner approved by the manufacturer to prevent clogging of screens, nozzles, and emitters.
- .10 Conduct mainline pressure test and HDPE pipe strap test and obtain approval from the consultant before backfilling lines.
- .11 Sidewall fusion of HDPE is not acceptable.
- .12 Set mainlines and laterals on and backfill them with sand to the clearance limit shown on the drawings.
- .13 Install thrust blocks at all changes in the direction of PVC pipe 64mm in diameter or greater and for any change in the direction of gasketed pipe.
- .14 Install lateral piping at a depth of 300 mm to 600 mm (12" to 24").
- .15 Install mainline piping at a depth of 450 mm to 800 mm (18" to 32").

3.20 SLEEVING

- .1 Install irrigation sleeves in locations shown on Contract Drawings.
- .2 Install irrigation sleeve to depth as follows:
  - .1 Mainline Piping:
    - .1 600 mm below walkways
    - .2 900 mm below driveways, roads and plazas
  - .2 Lateral Piping:
    - .1 300 mm below walkways
    - .2 600 mm below driveways, roads and plazas
- .3 Install sleeves to extend 1.0 m past the edge of the hard surface into the soft landscape surface.
- .4 Cap sleeve with removable plug or cover. Maintain plug in sleeve until the pipe or wire is ready to be installed.
- .5 Bed sleeves as follows:
  - .1 Under walkways, 100 mm of sand is placed all around.

.2 Under driveways, roads, and plazas, compacted base aggregate all around per materials shown on Drawings.

.6 Bury a piece of detectable metal on top of each end of the sleeve to enable the location of the sleeve end by a metal detector after burial.

.7 Stake location of each end of the sleeve prior to backfilling such that the top of the stake is 300 mm above finished grade and maintained. Label the exposed end of the stake with the word "sleeve".

.8 Record the location of sleeve ends and label the size of the sleeve on record drawings.

.9 Remove the sleeve stake after submitting the Record Drawings.

### 3.21 VALVE BOXES

.1 Install manual and electric control valves, control zone kits, and quick coupler valves in valve boxes or concrete vaults, as shown on the Drawings.

.2 Except as shown otherwise on Contract Drawings or approved otherwise by the Consultant, locate valve boxes in planting beds and locate for ease of access, maintenance, and testing.

.3 Install the valve box flush with the finish grade and arrange it in a neat and orderly manner.

.4 Provide a minimum 50 mm clearance between the valve box and all components within.

.5 The valve box must not contact the irrigation pipe. Use 300mm height-matching valve box extensions as required.

.6 Up to three (3) 25 mm control valves or two (2) 38 mm control valves may be contained within a single valve box provided 100mm of clearance between valves. Install valves 50 mm and larger in their own valve box.

.7 Install a minimum of four (4) bricks below all corners of the valve box. The bricks shall not intrude into the valve box's space.

.8 Wrap all valve boxes in landscape fabric before burial to prevent material from sloughing into the valve box.

### 3.22 ELECTRICAL CONTROL VALVE

.1 Install in valve box per manufacturer's recommendations and Contract Drawings.

.2 Identify the electric control valve with a permanent label or tag indicating the zone number of the valve.

.3 Install a 25 mm Schedule 40 PVC ball valve upstream of each 25mm; for larger valves, install a gate valve sized to match the valve.

.4 Ensure a 50 mm gap between the bottom of the valve and the top of the drain rock.

.5 Install valve box on bed 150mm depth of 25mm drain rock that extends 100mm past all edges of the valve box.

### 3.23 SWING JOINT ASSEMBLY

.1 Fabricate the assembly of a triple swing joint using three threaded Schedule 40 PVC elbows and one threaded Schedule 80 PVC nipple for sprinklers flowing more than 8gpm and preassembled Rain Bird swing joint assemblies for sprinklers flowing up to 8gpm.

.2 Install swing joint assembly to rotate counterclockwise when depressed.

.3 Tape threads of PVC fittings with Teflon tape and make hand tight.

.4 Install pre-fabricated swing joints per the manufacturer's recommendations.

### 3.24 SPRINKLERS

.1 Install per manufacturer's recommendations and in the location shown on Contract Drawings.

.2 The location of heads, as illustrated on the Contract Drawings, is intended as a guide to the layout of heads. Establish actual head locations in the field to ensure complete and adequate coverage of all areas to be irrigated and no overspray onto adjacent surfaces and improvements. Do not exceed the head spacing shown on the Contract Drawings.

.3 Where obstructions or site improvements hinder or block head-to-head coverage, advise the Consultant and determine the best method to maximize coverage.

.4 For flat surfaces, install head plumb to finished grade. For sloped surfaces, install a head perpendicular to half the grade of the slope.

.5 Mount pop-up heads on the triple swing joint assembly. Connect the sprinkler's bottom inlet to the swing joint assembly, not the side inlet. Adjust the swing joint assembly to set the head flush with the finish grade. Tape the threads of the PVC fittings with Teflon tape and make the hand tight.

.6 Adjust arc, the radius of coverage and flow at each sprinkler to achieve even head-to-head coverage of the area to be irrigated, with minimum over-spray onto other surfaces.

### 3.25 ROOT WATERING SYSTEM

.1 Install root watering system as follows:

- .1 Install sock over the canister.
- .2 Position units evenly spaced around the root ball and adjacent to the root zone within the tree canopy.
- .3 Fill the canister with pea gravel to 50mm below the bubbler.
- .4 Connect to lateral pipe with Rain Bird SPX Series Swing Pipe and Rain Bird SB Series Spiral Barb fittings.
- .5 Cover the grate with duct tape or landscape fabric to prevent the ingress of foreign material during construction. Remove it prior to Substantial Performance.

### 3.26 DRIP ZONE KITS

.1 Install in valve box per manufacturer's recommendations and Contract Drawings.

.2 Identify the electric control valve with a permanent label or tag indicating the zone number of the valve.

.3 Drip zone kits shall include one (1) schedule 40 PVC ball valve and filter.

.4 Drip zone kits are to include a ball valve, filter, and pressure regulating module.

.5 Ensure a 50mm gap between the bottom of the valve and the top of the drain rock.

.6 Install valve box on bed 150mm depth of 25mm drain rock that extends 100mm past all edges of the valve box.

### 3.27 FILTERS

.1 Install the filter in the same valve box as a valve, per the manufacturer's recommendations and Contract Drawings.

### 3.28 LANDSCAPE DRIPLINE

.1 Do not install driplines or emitters of different flow lengths or spacing on the same zone.

.2 Place the dripline on the prepared surface. The surface must be free of sharp rocks or other objects that may damage it. It must also be at the grade necessary for the dripline to be at the specified depth after the remainder of the topsoil or growing medium is placed.

.3 Placement of dripline by trenching using hand or mechanical methods permitted only if specified as such on Contract Drawings or upon written approval of the Consultant.

.4 Thoroughly flush each zone after installation and before beginning regular operation of the drip zone.

.5 Stake dripline in beds every 450 mm on centre.

.6 Make all zone connections and test the manifold, lines, and fittings for leaks prior to placing topsoil or growing medium over the manifold, headers, dripline, and emitters.

### 3.29 DRIP EMITTERS

.1 Install per manufacturer's recommendations and as shown on Contract Drawings.

### 3.30 LATERAL FLUSH ASSEMBLY

.1 Install flush assembly on the swing joint in the valve box.

.2 Install flush valve assembly at the end of each leg or section of drip line and at the end of each leg of lateral on a root watering system zone.

### 3.31 AIR RELIEF VALVE

.1 Install an air relief valve at the highest point in the zone or bed.

### 3.32 THRUST BLOCK

.1 Place a thrust block to support the pipe joints from separating, not to prevent the pipe from heaving. Do not cover the top of the pipe with concrete thrust blocking at change from a horizontal alignment to a vertical alignment.

.2 For thrust blocks installed in disturbed soils, increase the thrust block area by 50%.

.3 Place 2 ply of 6 mil polyethylene between the pipe and thrust block.

.4 Allow the concrete to set before backfilling the trench or pressurizing the line.

.5 Obtain approval from the Consultant before backfilling the thrust block.

### 3.33 CLEAN-UP AND RESTORATION

.1 Remove all waste and debris from the site resulting from irrigation installation.

.2 Restore all disturbed surfaces to original condition or better, and repair all trench settlements.

### 3.34 INSTRUCTIONS TO CITY (OWNER)

.1 Instruct the City in complete operating and maintenance procedures for the irrigation system, including start-up, winterization, and programming.

.2 Review Record Drawings and Operating Manual with the City on site.

### 3.35 GENERAL MAINTENANCE

.1 Inspect, operate, maintain, and adjust the irrigation system through the Landscape Maintenance Period until issuance of Certificate of Acceptance to ensure it operates as intended, including but not limited to:

- .1 Adjust irrigation schedule to ensure survival, health and growth of plant material and respond to soil conditions, and climate.
- .2 Clean sprinkler heads and adjust coverage to eliminate over watering, under watering and overspray onto adjacent surfaces.
- .3 Monitor and clean filtration equipment.
- .4 Restore grass areas, planting beds, and hard surfaces, as well as improvements affected by trench settlement and erosion.
- .5 Respond to requests from the Consultant for program adjustments, servicing, adjustments, and repairs.

### 3.36 WINTERIZATION MAINTENANCE

.1 During the Maintenance Period, be responsible for the winterization of the irrigation system at the end of the growing season and before the onset of air temperatures below 01 Celsius. Be liable for any damage resulting from late or improper winterization.

.2 Request the presence of the City at winterization at least 5 days prior to the proposed winterization date.

.3 Winterization includes but is not limited to:

- .1 Deactivation of controller
- .2 Drainage and blow-out assembly of the entire irrigation system.

### 3.37 MAINTENANCE SPRING START-UP

.1 During the Maintenance Period, be responsible for the spring start-up of the irrigation system at the beginning of the growing season or within 10 days of the request for start-up from the City. Be liable for any damage resulting from late or improper start-up.

.2 Ensure the City is present for spring start-up. Request the city's presence at least five (5) days before the proposed start-up.

.3 Spring start-up includes but is not limited to:

- .1 Checking and testing for leaks.
- .2 Cycling irrigation control program through all zones to ensure proper function and performance.
- .3 Checking and adjusting heads and emitters to achieve even coverage with minimum overspray onto other surfaces.
- .4 Test backflow prevention assembly. Submit test results to the Consultant.
- .5 Saturation of soil with water to a depth of 300 mm to provide deep watering of all lawn areas, planting beds and tree pits

### 3.38 GUARANTEE

.1 Submit a written guarantee, in approved form, stating that all work showing defects in materials, workmanship or operation will be repaired or replaced at no cost to the City for a period of one (1) year from the date of Substantial Performance.

.2 Guarantee includes the supply of labour, materials and equipment necessary for the repair and replacement of damaged or defective materials and workmanship. Guarantee also includes spring start up, winterization, maintenance, necessary testing, program corrections or adjustments and restoration of settled trenches.

.3 Guarantee will not apply to materials or workmanship damaged after Substantial Performance by causes beyond the Subcontractor's control, such as vandalism or abuse.

**END OF SECTION**

STORM SEWERS

<b>1.6 Measurement and Payment</b>	Delete 1.6.1 and replace with the following	Payment for storm sewer will be made at the unit price bid for storm sewer (regardless of depth) consistent with pipe materials, diameters and backfill requirements shown on the Contract Drawings and described under individual payment items in the Schedule of Quantities.
	Delete 1.6.2 and replace with the following	Payment for storm sewers includes trench excavation, dewatering, bypass pumping, on-site reuse of surplus/displaced material, removal and disposal of existing pipes, supply and installation of all pipe, wyes, cap, fittings and related materials, tie-ins to existing or new storm pipe or manhole other than noted in Clause 1.6.9, construction joints, bedding, import backfill, native backfill, granular base, granular Subbase, cleaning and flushing, testing (if applicable), videoing and all other work and materials necessary to complete installation as shown on Contract Drawings and specified under this Section; and  Measurement for storm sewer will be made horizontally from manhole centerline to manhole centerline over surface work has been completed.  Native excavated material approved for re-use as trench backfill shall be at the sole discretion of the Contract Administrator. All cobbles greater than 150 mm diameter removed and disposed off-site and shall be granular in nature and free from organic materials. Native excavated material shall not be used as trench backfill where moisture content does not permit compaction to specified density. Where native excavated material is unacceptable for use as trench backfill, imported trench backfill shall be supplied, placed, and compacted to specified density.  Payment for concrete driveway and curb & gutter will be made under Section 03 30 20S.  Payment includes by-pass pumping to include all pumps, labour and materials required to facilitate the work. Payment for the by-pass pumping will be incidental. Measurement for storm sewer will be made along the ground from the start of new pvc pipe to the terminus of the new pvc pipe.
	Delete 1.6.3 and replace with	Payment for new service connections includes 150mm SDR28 PVC pipe, shear band couplers, bends, increaser, pvc wye, stubs, caps, sanded stubs, manhole preparation, inserta tee, Le-Ron inspection chamber c/w locking collar and green lid and all related fittings and components specified and/or shown on Standard Detail Drawings. Payment includes all applicable service pipes, materials and work described in 1.6.2.  Measurement for service connection will be for each complete service installed, including the inspection chamber, length of service pipe installed and length of riser.
	Add 1.6.3.1	Payment for storm service connection repair/replacement includes 150mm SDR28 PVC pipe, shear band couplers, bends, sanded stubs, inserta tee, increaser, stubs and all related fittings and components specified and/or shown on Standard Detail Drawings. Payment includes all applicable service pipes, materials and work described in 1.6.2 unless specified otherwise in the Schedule of Quantities and Prices.

STORM SEWERS

	<p>Measurement and payment for storm lead repair/replacement will be made at the unit price bid per lineal meter of service lead installed as measured along the ground from the downstream end of work done in Clause 1.6.4 to the terminus of the repair.</p>
<p>Delete 1.6.4 and replace with</p>	<p>The lump sum payment is to supply and install Le-Ron molded storm inspection chambers c/w locking collar &amp; green lid including the riser as per COQ-S7A, COQ-S8A and MMCD S9 at each location. The tendered price is to include all labour, shear band couplers, 2m PVC SDR 28 pipe stubs and all related fittings and components specified and/or shown on Standard Detail Drawings and all such other items that may be required to complete the work as specified. Payment includes all applicable materials and work described in 1.6.2.</p> <p>A City crew will be inspecting the service connection by hand video prior to the Contractor's installing the IC. The Contractor shall notify the City inspector once the section of the service connection is ready for hand video. Payment includes assisting City crew in hand videoing the service connection. Based on the hand video result, City assessment or apparent condition of the pipe, repair/replacement is to be done under Clause 1.6.3.1. Repair/replacement shall only be done as approved by Contract Administrator or City inspector.</p> <p><b>NOTE: Depth specified on the utility connection record without an IC is typically measured from the top of the clean out wye.</b></p> <p>Brooks Boxes with a steel lid are to be provided for inspection chambers located in driveways as necessary. Payment for the Brooks Boxes on a driveway will be incidental.</p> <p>Payment includes support of poles if necessary and manhole barrel preparation to accommodate the service connection.</p>
<p>Delete 1.6.5 and replace with the following</p>	<p>Payment for catchbasin or lawn basin leads include all applicable materials and work described in 1.6.2. Payment for removal and disposal of perforated drainpipe will be considered as incidental.</p> <p>Measurement for catchbasin leads or lawn basin leads will be made horizontally from mainline pipe to centreline of catchbasin or lawn basin for each pipe size installed with no regards to depth range.</p>
<p>Delete 1.6.6 and replace with the following</p>	<p>Payment for boulevard retention trench includes all applicable materials and work described in 1.6.2, and will include excavation, removal and disposal of excavated or displaced material, pvc decant or dispersal piping, trench dam, clean out, perforated pipe, solid pipe under driveways, growing medium, tie-in into catch basins/lawn basins and/ or storm sewer, drain rock, fittings, filter fabric surround and all other work incidental to complete the work as shown on the Contract Drawing and COQ-SW3 / COQ-SW4.</p> <p>Payment for catch basins and lawn basins will be made under Section 33 44 01S – Clause 1.5.2.</p>
<p>Add 1.6.12</p>	<p>Payment for removal of perforated drainpipe and replacement with 150mm PVC DR28, tied into existing subdrain includes applicable materials and work as described in 1.6.2 and 1.6.6 of this Section and will include PVC pipes, gravel, etc. complete.</p>

STORM SEWERS

<b>2.0</b>	<b>PRODUCTS</b>		
<b>2.2</b>	<b>PVC Pipe, Mainline Smooth Wall</b>	Delete 2.2.1 pipe size ranges and replace with the following	200 mm dia. – 375 mm dia. to ASTM D3034 450 mm dia. – 1,200 mm dia. to ASTM F679
<b>2.3</b>	<b>PVC Pipe, Mainline Profile</b>	Delete 2.3	
<b>2.6</b>	<b>Service Connections</b>	Delete 2.6.1 and replace with the following  Delete 2.6.8.1  Delete 2.6.8.2 and replace with the following  Add 2.6.8.3	Storm service connections to be PVC DR 28 150 mm diameter minimum or as specified on <i>Contract Drawings</i> .  Connections to PVC pipe to be made with a performed wye fitting where mainline pipe is 300 mm diameter or smaller. For connections to PVC mainline pipe larger than 300 mm diameter an insertable tee for PVC pipe is permitted.  Insertable tee fitting shall have a rubber collar, which inserts into the mainline pipe to form a tight seal and shall have stainless steel band to secure the tee insert. The tee insert shall be a standard bell end with depth control lugs. The joint shall provide a minimum seal of 90 kPa on concrete and polyethylene pipe, and 190 kPa on PVC pipe.
<b>2.9</b>	<b>Granular Pipe Bedding and Surround Material</b>	Delete 2.9.3	Pipe bedding shall be 19 mm clear crushed rock or as approved by the <i>Contract Administrator</i> and the City.
<b>3.0</b>	<b>EXECUTION</b>		
<b>3.8</b>	<b>Connections to Existing Mainline Pipe</b>	Delete 3.8.3 and replace with the following	For new connections to existing, smooth wall or profile, mainline sewers 300 mm and smaller, shall be made by removal of the section of the main and replacement with a preformed PVC wye fitting complete with stubs and double hub PVC couplings for PVC mains and approved shear band couplings for other mainline materials.  For new connections to existing mainline greater than 300 mm, use of insertable tee will be permitted.
<b>3.10</b>	<b>Service Connection Installation</b>	Delete 3.10.3 replace with the following	Inspection chambers shall be provided on all storm service connections as per Standard Detail Drawing S7. If inspection chamber is located in driveway, lane, or paved surface, Series 37 Brooks concrete box with lid shall be installed as per Standard Detail Drawing S9.
<b>3.12</b>	<b>Inspection and Testing</b>		The contractor shall video inspect completed storm sewers under 900 mm in diameter and all service connections following completion of the installation. The video inspection report shall be in a form specified by the Contract Administrator and the City. Copies of the video DVD and written report shall be forwarded to the Contract Administrator and the City. Refer to Section 33 01 30.1 and 33 01 30.1S CCTV Inspection of Pipelines.
<b>3.16</b>	<b>Permanent Capping of Service Connections</b>	Add 3.16.1	Permanent capping of existing storm sewer connections to be completed as per Coquitlam Standard Detail Drawing COQ-S18.

**STORM SEWERS**

---

Add 3.16.2

A trenchless method of permanently capping a service may be required on an arterial road or on a road, which has been paved within 5 years, as directed by the Manager.

The trenchless technology used to cap the service must be approved by the Manager.

**END OF SECTION**

MANHOLES AND CATCHBASINS

1.0 GENERAL

1.1	<b>Related Work</b>	Add 1.1.6	Hot Mix Asphalt Concrete Pavement	Section 32 12 16
		Add 1.1.7	Portland Cement Concrete Paving	Section 32 13 13
1.5	<b>Measurement and Payment</b>	Delete 1.5.1 and replace with the following	<p>Lump sum payment includes all labor, material and equipment required to complete the installation as shown on Contract Drawings and specified under this Section. Payment includes subgrade preparation, compaction of base material, all in-situ concrete work, supply and installation of concrete base, lid suitable for H2O loading and as per City standard, metal frame, concrete lid, barrel and riser sections including ladder rungs, manhole benching, and all associated works as shown on the Contract Drawings and as described in Schedule of Quantities and Prices.</p> <p>Payment includes manhole preparation to accommodate tie-ins, excavation, disposal of surplus excavated material, base preparation, bedding and import backfill.</p> <p>No payment will be made under this item carried out as part of operation of items described in other Sections.</p>	
		Delete 1.5.2 and replace with the following	<p>Payment includes supply and installation of new catchbasin/lawnbasin as described in Schedule of Quantities and Prices including catch basin base, concrete barrel, concrete riser, pvc sanded stub, donut ring, off-set sump, H2O rated concrete frame/lid, metal frame, top inlet and grate, aluminum trapping hood and all labor, material and equipment required to complete the work from specified invert to finishing level and as per Standard Detail Drawing as described in Schedule of Quantities and Prices. Payment includes excavation, disposal of surplus excavated material, base preparation, bedding, import backfill, catchbasin/lawnbasin preparation to accommodate catchbasin/lawnbasin connection, installation of all in-situ concrete work, all labor, material, equipment and necessary work for installing the catchbasin/lawnbasin.</p> <p>Catchbasin/lawnbasin lead work will be made under Section 33 40 01S – Clause 1.6.5.</p>	
		Delete 1.5.3 and replace with the following	<p>Adjustment of tops of existing units will be measured in units adjusted as defined below and paid for under their respective Item in the Schedule of Quantities.</p> <p><u>No payment will be made under these items for cleaning Valve Boxes, Monument Boxes, Manhole Frames &amp; Covers and Lids of Castings as part of the operation for asphaltic concrete paving.</u></p> <p><u>No Payment will be made for adjusting External Utilities Valve Boxes, Monument Boxes, Gas valve boxes, Lawn Drains, Cleanouts and Inspection Chambers, these adjustments will be treated as incidental work unless otherwise specified.</u></p> <p><u>All manholes &amp; valve boxes must be vertically adjusted a minimum of 24 hours prior to paving.</u></p> <p>1. Manhole frames and lids adjustment and replacement will be defined as supplying and installing a new manhole frame and lid and setting to the finished grade. Adjustments and replacements shall include</p>	

MANHOLES AND CATCHBASINS

jackhammering, removal and disposal of the existing frame and lid, replacement, removal of concrete bricks, addition or removal of precast concrete riser rings, cement mortar, supply and installation of new manhole frame and lid set to final grade, temporary asphalt ramping and all other incidental work.

Manhole frames and lids adjustments ONLY is the re-use of existing frames and lids and all the necessary work as described above.

2. Water Valve Box replacements will be defined as supplying and installing a new Nelson Type Terminal City Water Valve Box frame & lid and setting to the finished grade. Replacements shall include jackhammering, removal and disposal of the existing frame and lid and all other incidental work. Adjustment of water valves on existing or new watermain
3. Catchbasins frame and lid replacement will be defined as setting as supplying and installing a new catchbasin frame & lid to the correct elevation. Adjustments shall include jackhammering, removal of the existing grating and frame and all other incidental work. Payment includes excavation, disposal, removal of concrete bricks, removal or addition of precast concrete riser rings, cement mortar, disposal of surplus excavated material, cast-in-place concrete, pipes, fittings and related materials together with all labour, materials and equipment required. Catch basin lead work is considered to be incidental to payment for catch basin lead work described in other sections.

The use of Steel/Metal Casting Risers Rings will not be accepted to adjust manholes or water valves to the final asphalt elevation.

**2.0 PRODUCTS**

- |                      |  |   |
|----------------------|--|---|
| <b>2.1 Materials</b> | Add 2.1.7.3                                  | Any frame and cover assembly creating a point load on the concrete riser rings will not be permitted. |
|                      | Delete 2.1.12 and replace with the following | Catchbasin lids manufactured to ASTM C478M  |
|                      | Delete 2.1.16.2                              |   |
|                      | Delete 2.1.17                                |   |

**3.0 EXECUTION**

- |                                    |  |  |
|------------------------------------|--|--|
| <b>3.1 Excavation and Backfill</b> | Add 3.1.2                                      | For manholes, when base gravels are complete, excavate for grade rings and manhole frame assembly. Do not disturb the compacted road base beyond the excavation requirement. |
| <b>3.3 Manhole Installation</b>    | Delete 3.3.12.2 and replace with the following | Allowable products are precast concrete risers and cast-in-place form system. Individual riser heights shall be 50mm, 75mm, or 100mm.  |
|                                    | Delete 3.3.12.5 and replace with the following | Proper layer of grout between the spacers, covering the entire surface of the rings, should be utilized.   |

**MANHOLES AND CATCHBASINS**

	Delete 3.3.15 and replace with the following	Install drop structures as shown on the contract drawings to Coquitlam Standard Detail Drawing COQ-S4 and Standard Detail Drawing S3. Maximum allowable inside ramp shall be 250 mm invert to invert.
	Delete 3.3.17 and replace with the following	Ensure frames conform to design contour of pavement or existing surface. Manhole lids left raised in preparation for overlay paving shall have a rubberized protector ring or asphalt ramp. The use of riser rings for adjusting manhole frames will not be permitted.
<b>3.5</b>	<b>Catchbasin Installation</b>	Delete 3.5.1 and replace with the following
		Install catchbasins as shown on Coquitlam Standard Detail Drawings COQ-S11A, COQ-S11B and Standard Detail Drawing S11, to general standards and installation procedures described under 3.3 of this Section.

**END OF SECTION**

TRAFFIC SIGNALS

1.0 GENERAL

1.3 **Shop Drawings** Delete 1.3.4 and replace with the following  
Shop drawings for pole structures, where required, to be sealed by a Professional Engineer registered in British Columbia.

1.4 **Electrical Energy Supply** Add 1.4.4  
The Electrical *Contractor* will process a letter of application to the City of Coquitlam for the Utility Company and attain all required permits.

1.5 **Contractor Qualifications** Add 1.5.3  
All on-site traffic signal installations shall be under the responsibility of a primary journeyman electrician with IMSA Level 2 Signal Certification and have successfully completed at least five (5) traffic signal system installations. This primary journeyman electrician is expected to have to be at the *Place of Work* and report work progress to City of Coquitlam's Traffic Operations staff, in addition to reporting to the *Contract Administrator*.

Add 1.5.4

Fibre Optic Cable:

- .1 All fibre optic cable installations workmanship, material and/or installation practices and activity will be equal to or better than the standards established by the CAN/CSA T529-530-M90 Standards and the Canadian Electrical Code.
- .2 Those retained to complete the work must be authorized, trained and certified by the manufacturers they represent. They must have a minimum of two (2) years experience installing and testing multimode and single mode cables of all types as well as experience with LC and SC connectors.
- .3 Those retained to complete the work must have experience installing cabling for FDDI (Distribution System Data Interface) compliant 100 Mbit/sec, SONET, ATM, Token Ring or Ethernet networks using industry accepted systems and practices. Experience with leading manufactures fiber products and systems would be beneficial.
- .4 Those retained to complete the work must be prepared, trained and equipped to properly test the fibre cabling system, including the fibre transmission media and connectors. Each optical fibre of each section of cable will be tested using an "Optical Time Domain Reflectometer" (OTDR) and will meet the specifications before installation. After installation an "Optical Light-loss Testing Sets" (OLTS) will be mandatory to determine cable length, locate any fibre breaks or anomalies, measure attenuation of fibre's, connectors and assess fibre uniformity. Those retained to complete the work will provide a report showing all values measured during these tests.

1.6 **Permits and Tests** Add 1.6.5  
*Contractor* shall provide the BC Safety Electrical Permit, and arrange all inspections with the City. The inspection entails, but not limited to, Coquitlam's "Intersection and Cabinet Start-up Checklist", which can be obtained from Coquitlam's Traffic Operations staff.

2.0 PRODUCTS

2.1 **General** Delete 2.1.2 and replace with the following  
All products supplied to be new, in accordance with *Contract Documents*. All products are to meet Canadian Electrical Code requirements and be certified by either CSA, UL®, or Intertek Testing Systems (Warnock Hersey) and be supplied with the certifier's label.

TRAFFIC SIGNALS

		Delete 2.1.3 and replace with the following	All products shall be in accordance with the City of Coquitlam's List of Approved Materials and Products List. Any products not listed with in the Approved List shall default to the current BCMOTI specification.
		Delete 2.1.5 and replace with the following	Equipment models listed within the City of Coquitlam's List of Approved Materials and Products shall be confirmed with the City immediately prior to their order to ensure that they are current. Cut-sheets, equipment make, model and serial number list to be provided to the City by the <i>Contractor</i> for each traffic signal location. Material supplied by City of Coquitlam and installed by <i>Contractor</i> , shall be shown in the <i>Contract Documents</i> .
2.2	Conduit	Add 2.2.1.3	All exposed metallic surfaces to be hot dip galvanized.
2.3	Trench marker Tape	Add 2.3.2	Detectable (manetic) market tape shall be used in all trenches containing interconnection (communications) conduit.
2.5	Concrete Junction Boxes	Delete 2.5 and replace with the following	Refer to the City of Coquitlam's List of Approved Materials and Products. For Concrete Vaults: Refer to Coquitlam Standard Detail Drawing SS-E2.5.
2.8	Conductor Tags	Delete 2.8 and replace with the following	Refer to the City of Coquitlam's List of Approved Materials and Products.
2.10	Fuse and Fuse Holders	Delete 2.10 and replace with the following	Refer to the City of Coquitlam's List of Approved Materials and Products.
2.11	Service Panels	Add 2.11.5	Refer to the City of Coquitlam's List of Approved Materials and Products.
2.16	Traffic and Pedestrian Signals	Delete 2.16.1 and replace with the following	Traffic signal heads to be yellow polycarbonate with 300 mm round signal indications, and conform to Section 601 Signal and Pedestrian Heads BCMOTI E&SMS V1. All primary and secondary signal heads shall have yellow aluminum backboards with 75 mm border of yellow prismatic retro-reflective sheeting (3M™ Scotchlite™ Diamond Grade™ VIP Reflective Sheeting Series 3990 or approved alternate).
		Delete 2.16.2 and replace with the following	Fire signal head assembly as per Coquitlam Standard Detail Drawing SS-E5.19.
		Add 2.16.3	Signal head backboards with plumbizer gaps or knock out sections will not be accepted for adjustable bracket signal head mounting method.
2.17	LED Signal Modules	Delete 2.17 and replace with the following	Refer to the City of Coquitlam's List of Approved Materials and Products.
2.19	Signal Mounting Hardware	Add 2.19.8	Primary signal head safety cable to be 3/32" galvanized steel aircraft cable.
		Add 2.19.9	Refer to the City of Coquitlam's List of Approved Materials and Products.
2.20	Audible Signals	Delete 2.20 and replace with the following	Refer to the City of Coquitlam's List of Approved Materials and Products.

TRAFFIC SIGNALS

2.21	Pedestrian /Cyclist Pushbuttons	Delete 2.21 and replace with the following	Refer to the City of Coquitlam’s List of Approved Materials and Products.
2.22	Luminaires	Add 2.22.6	Refer to the City of Coquitlam’s List of Approved Materials and Products.
2.29	Illuminated Crosswalk Signs	Delete 2.29 and replace with the following	Refer to the City of Coquitlam’s List of Approved Materials and Products. Illuminated sign safety cable to be 3/32” galvanized steel aircraft cable.
3.0	EXECUTION		
3.1	General	Add 3.1.5	During the installation of the traffic signal system, maintain the existing traffic signal and/or signs as noted on the <i>Contract Drawing</i> . If temporary or permanent relocations of related traffic signal equipment or signs are required, such equipment shall be reinstated as required under the <i>Contract Documents</i> or as directed by the <i>Contract Administrator</i> .
3.3	Concrete Bases	Add 3.3.7	Concrete service bases detailed on Standard Detail Drawings CE1.3 and CE1.4, Type C1 and C3 service bases shall have five (5) conduits. See Coquitlam Standard Detail Drawing SS-E7.3.
		Add 3.3.8	Lifting cables on concrete controller bases shall be removed after base installation.
		Add 3.3.9	All concrete bases shall be pre-cast concrete only, unless noted on <i>Contract Drawing</i> or directed by the <i>Contract Administrator</i> .
3.4	Junction Boxes and Vaults	Delete 3.4.1 and replace with the following	Install junction boxes as shown on Standard Detail Drawings E2.2 to E2.4. Install vaults as shown on Coquitlam Standard Detail Drawing SS-E2.5.
		Add 3.4.5	Bell end fittings shall be installed in all conduits entering junction boxes or vaults.
		Add 3.4.6	Junction boxes requiring 3 or more sections must be approved by the City of Coquitlam’s Traffic Operations staff.
		Add 3.4.7	All junction boxes shall be provided with RPVC bars to support electrical connections and fuse holders. The RPVC bars shall be attached into the junction box side walls with the electrical connections/fuse holders tie-wrapped in place and installed in the up-right position.
3.5	Underground Conduit	Delete 3.5.2 and replace with the following	Minimum cover over conduits to be 600 mm in boulevard areas and 900 mm in roadway areas, unless otherwise specified in the contract documents.

**TRAFFIC SIGNALS**

		Delete 3.5.3 and replace with the following	Place trench marker tape 300 mm above installed conduit in trench. Trench marker tape not required for conduits installed via trenchless technology.
		Delete 3.5.5 and replace with the following	Empty conduits shall have a No. 8 HB Yellow/Green Mk pull string and capped at both ends.
		Add 3.5.6	Conduit run shall contain no more than the equivalent of 4 – 90 degree bends.
		Add 3.5.7	Conduits shall be blown out with compressed air, from both ends if necessary, then swabbed out to remove stones, dirt, water and other material, which may have entered during installation.
		Add 3.5.8	All conduits entering poles and cabinets shall be sealed with “Duct Seal”.
		Add 3.5.9	Conduit depth of bury to be recorded when a trenchless technology method is used.
		Add 3.5.10	Traffic signal communications conduit shall enter and leave junction boxes through bell end fittings in the horizontal position (no bends) and shall run straight through the junction box unless a change in alignment occurs, or as otherwise specified on the <i>Contract Drawing</i> .
		Add 3.5.11	Conduit shall not be bent in the field. Only factory bends will be accepted.
<b>3.7</b>	<b>Traffic Signal and Pedestrian Head Mounting</b>	Delete 3.7.1 and replace with the following	Install traffic signal and pedestrian signal heads as shown and Standard Detail Drawings E5.2 and E5.9 only. Banding straps shall be used for primary signal heads.
		Add 3.7.5	Primary traffic signal heads shall be safety cabled to the traffic signal pole arm using 3/32” galvanized steel aircraft cable looped through the traffic signal backboard and fastened with a rope clip.
<b>3.8</b>	<b>Audible Signals</b>	Delete 3.8.1 and replace with the following	Install audible signal in accordance with Coquitlam Standard Detail Drawing SS-E5.12.
<b>3.10</b>	<b>Luminaires and Photocells</b>	Add 3.10.4	NEMA wattage label shall be visible at the bottom of the luminaire on all fixtures.

**TRAFFIC SIGNALS**

<b>3.13</b>	<b>Electrical Service Panels</b>	Delete 3.13.1 and replace with the following	Mount electrical service panels in service base or on poles as shown on Standard Detail Drawings E7.2, E7.6 to E7.9, as well as Coquitlam Standard Detail Drawings SS-E7.3 to SS-E7.5.
<b>3.14</b>	<b>Wiring</b>	Delete 3.14.3 and replace with the following	With the exception of conductor spliced of detector loop wires to shield cables, make conductor splice in pole handholes. Make splices of detector loop wires to shielded cable in junction boxes.
		Delete 3.14.13 and replace with the following	Bond all signal heads and luminaires with No. 12 RW90 green conductor, and steel junction box lids with No. 8 RW90 green conductor.
		Add 3.14.14	Detector loop cable splices shall be soldered with rosin core solder (no acid core or acid flux) then cap with waterproof gel filled wire nut and tape with vinyl di-electric tape. Suspend and ty-wrap splices at top of junction box with open end of wire nut pointing down. Loop shield drain conductor shall cut and be isolated from the system ground. See Coquitlam Standard Detail Drawing SS-E8.4.
<b>3.16</b>	<b>Traffic Controller</b>	Add 3.16.8	Silicone sealant shall be applied to both sides of the rubber gasket, which is placed between the traffic signal cabinet and the concrete base to ensure a weather tight seal.
		Add 3.16.9	Traffic cabinet interior shall be kept dry during inclement weather.
<b>3.19</b>	<b>Advance Warning Signs</b>	Add 3.19.2	Contrary to Standard Detail Drawing E10.3, Item A shall be a 300 mm signal head section with LED display.
		Add 3.19.3	Advance warning signs shall have yellow prismatic retro-reflective sheeting (3M™ Scotchlite™ Diamond Grade™ VIP Reflective Sheeting Series 3990 or approved alternate).
<b>3.20</b>	<b>Grounding &amp; Bonding</b>	Add 3.20.5	Ground plates and grounding conductors are to have a minimum of 5 meters clearance between them and other utility grounding.
		Add 3.20.6	Grounding rod or plate electrodes shall not be installed inside the traffic signal cabinet base.
		Add 3.20.7	Remove all paint around bonding studs on inside of pole to expose the galvanized or metal surface prior to bonding equipment.
<b>3.22</b>	<b>Pole Finish Application</b>	Delete 3.22 and replace with the following	<p>.1 Prior to producing a powder finish product the supplier must provide a Certificate of Compliance indicating that they have met or exceeded the following specifications. The supplier will name their independent testing agency and this information will be submitted to the City for their files.</p> <p>.2 The application process will be as follows:</p>

TRAFFIC SIGNALS

- .1 The pole or product will be hot dip galvanized.
  - .2 Powder will only be applied after the product is completely fabricated. No welding or bending will take place after the powder is applied.
  - .3 The pole or product will be thoroughly cleaned by brush blasting in accordance with SSPC-SP7. The brush blast will maintain a minimum profile of 0.5 mils. If brush blasting is done off site then the product will be covered and shielded from any dirt or moisture during its return to the powder applicators facility. Where poles or products are not kept clean and dry or have any signs of flash rust they will be returned for further brush blasting.
  - .4 Once at the applicators facility the pole or product will be thoroughly cleaned and dried with an air gun. All hand marks or grease spots will be cleaned with a mild solvent.
  - .5 After brush blasting the entire pole or product will be pre-baked in an oven at 220 degrees C for at least 30 minutes to 1 hour, depending on steel thickness. The pre-baking must be done to prevent out-gassing during the curing cycle.
  - .6 The base powder coat will then be applied electrostatically while the pole or product is cooling from the 220 degrees C pre-bake period to allow the powder to melt and fuse to the surface. The base coat will be a minimum of 3 mils in thickness.
  - .7 After base coat is applied and set the topcoat will be applied to a thickness of 3 to 5 mils. The pole or product will be returned to the oven and heated to 190 to 220 degrees C (temperature will not exceed pre-bake) for a minimum of 25 minutes, depending on steel thickness. Thicker product material may require longer bake cycles to fully cure. Upon removal of the pole or product from the oven it will be left to rest until the pole or product is cool enough to the touch.
  - .8 Once the topcoat has cured and the poles or product cooled, they will then be individually wrapped (min 4" overlapping method) with 1/8" foam wrap over the entire pole or product. The poles or product will be bundled together and separated with suitable wood dunnage to avoid contact between the poles, product or other bundles. All bundles themselves will be fully wrapped with foam and with stretch-wrap as noted above. The poles or products will be handled and shipped with great care to prevent damage; damaged product will be cause for rejection of the item(s).
- .3 Testing process will be as follows:
- .1 Each run of product in an oven will have at least one sample tested for:
  - .2 Adhesion – The finished powder surface will have minimum pull-off strength exceeding 1000 PSI as tested in accordance with ASTM D4541.
  - .3 Quality – The finished powder surface will be free from any holidays (skips or misses) as tested in accordance with ASTM D4541. The product will also be free from wrinkles, orange peel, cracking, pinholes, fish eyes, blisters, etc by visual inspection.

TRAFFIC SIGNALS

			.4 Color – The color will be verified to be within 3 DE of specialized color.
			.5 An independent firm such as CanSpec Testing who are qualified to test powder finish will do the testing at the supplier’s expense. The result of tests must accompany the Certificate of Compliance and will be made available to the City or their representative upon request. A supplier who fails to test product as noted above will have their product rejected until the testing is completed and the product deemed acceptable by the testing agency.
			.6 Where the tested product fails on a given production run then a minimum of 30 % of the entire production run will be tested. If no other failures are found then the individual failed product will be stripped, reapplied and re-tested until it passes. If any of the 30% of product tested fails then the entire order will be stripped, reapplied and retested until it passes.
		.4	Field repairs will be undertaken as required to fix any scratches or imperfections in the final finish. Field repairs will be done as follows:
		.1	Feather the damaged area with sandpaper.
		.2	Clean area with solvent.
		.3	Let dry.
		.4	Neatly brush on an application of Aliphatic Urethane Acrylic Semi-Gloss High Build applied at 2-4 mils DFT over the entire sanded and damaged area. The ambient conditions will be dry and over 10 degrees C when the paint is applied.
		.5	The pole supplier will warranty the integrity of the surface for a minimum of 1 year from the date of installation. The warranty will include all labour and materials required to provide replacement product if required. The powder finish will be the responsibility of the pole supplier. The warranty will apply to fading, blistering, cracking or chipping of the surface.
<b>3.26</b>	<b>Uninterruptable Power Supply</b>	Add 3.26.2	Uninterruptable power supply/cabinet to be installed on the side of the traffic controller cabinet as detailed on the <i>Contract Drawing</i> and Coquitlam Standard Detail Drawing SS-E7.24.
<b>3.28</b>	<b>Illuminated Street Name Signs</b>	Add 3.28.1	Install illuminated street name signs as detailed on the <i>Contract Drawing</i> and Coquitlam Standard Detail Drawing SS-E5.18
		Add 3.28.2	Illuminated street name signs shall be safety cabled to the traffic signal pole arm using 3/32” galvanized steel aircraft cable.
<b>3.29</b>	<b>Emergency Vehicle Pre-emption</b>	Add 3.29.1	Emergency vehicle pre-emption system to be installed as detailed on the <i>Contract Drawing</i> and Coquitlam Standard Detail Drawing SS-E5.16.
		Add 3.29.2	Cable shall be continuous with a minimum of 2m of cable slack to be provided at each end, with no splices. Cabinet termination to be completed by City.

TRAFFIC SIGNALS

<b>3.32</b>	<b>Owner Supplied Materials</b>	Add 3.32.1	Those retained to complete the work must notify the City in writing (seven) 7 days prior to the time materials are required.
		Add 3.32.2	Unless otherwise noted, those retained to complete the work will make all necessary arrangements and pay all costs for the collection of the materials and for delivery to the <i>Place of Work</i> . They will assume responsibility for materials at the time they are picked up.
		Add 3.32.3	<p>Owner supplied materials generally consist of the following:</p> <ul style="list-style-type: none"><li>.1 Traffic controller equipment and cabinet.</li><li>.2 Uninterruptable power supply equipment and cabinet.</li><li>.3 Emergency pre-emption equipment.</li></ul> <p>The exact list of materials supplied by the Owner to be confirmed with the City of Coquitlam Traffic Operations staff and <i>Contract Administrator</i>. In the case of private development projects requiring City supplied materials, the cost for supply and installation of these materials will be borne by the Developer.</p>
<b>3.33</b>	<b>Fibre Optic Cable</b>	Add 3.33	<ul style="list-style-type: none"><li>.1 Fibre optic cables will be terminated to a twelve (12) port LC coupler panel.</li><li>.2 When installing Fibre Optic Communications Conduit, Fibre optic warning tape (150 mm wide orange plastic tape labelled "WARNING FIBRE OPTIC COMMUNICATIONS CABLE") and Detectable (Magnetic) marker tape is to be placed over all conduits containing fibre optic cable.</li><li>.3 During installation of new boxes or with all existing boxes ensure that they have been cleared of any soil, sand or gravel and other materials that have accumulated in the base of the junction box. Ensure that all empty conduits have a proper RPVC coupling and cap inserted (friction fit - DO NOT GLUE) into each duct. Once the conduit is populated, replace cap with bell coupling and glue in place.</li><li>.4 All communication conduits will be flushed with water and dried with compressed air. This process will be followed by pulling through a suitable size Blowing Mouse, a clean soft cloth and new No. 8 HB Yellow/Green Mk pull string</li><li>.5 Perform a visual inspection of the proposed cable route and be aware of any potential problem areas. Locations in which cables will be terminated must be inspected and plans made for hardware and cable slack storage. Space and access for termination of the cable should be considered prior to starting the job. Develop a cable placement plan based upon the cable route survey and your available equipment and personnel resources. Submit a plan to the City for acceptance prior to starting work.</li><li>.6 Be aware that any damage due to excessive pulling, bending, or crushing, may alter the cable's transmission characteristics to the extent that the cable section will have to be replaced at the Project's expense.</li><li>.7 Fibre optic cables will be installed in continuous runs in conduit between the traffic signal controller cabinets (no splices are allowed).</li></ul>

TRAFFIC SIGNALS

- .8 DO NOT EXCEED THE MINIMUM BEND RADIUS OF THE FIBRE. During installation do not exceed the minimum bend radius as specified by the manufacture.
- .9 DO NOT IMPROPERLY PULL OR EXCEED THE CABLE'S RATED PULLING TENSION as specified by the cable manufacturer. Excess pulling may not actually break the fibre, but it can cause the fibre attenuation to increase so that the installed system may not operate within the specified requirements.
- .10 DO NOT EXCEED THE VERTICAL RISE SPECIFICATION as specified by the cable manufacturer unless intermediate tension relief is used. Secure the cable to new or existing supports wherever possible.
- .11 Take precautions to protect reeled and unreeled cable from any source of damage, whether attended or unattended. Be particularly careful with pre-connected sections of cable produced to meet specific length requirements as any damage to the cable may require replacement of the entire section.
- .12 If the cable must be unreeled during installation, the "figure-eight" configuration should be used to prevent kinking or twisting. Do not coil the cable in a continuous direction except for lengths of 30 meters or less. The preferred size of the "figure-eight" is about 4.5 meters in length, with each loop about 1.5 meters to 2.4 meters in diameter.
- .13 If a cable puller is used, ensure that the recommended pulling tension of the cable is not exceeded. Do not pull through junction boxes, especially 90-degree conduit fittings, unless precautions are taken to maintain the minimum bend radius.
- .14 When installing cable in conduits, ensure the conduit does not exceed the minimum bend radius. Avoid pull boxes unless the maximum bend radius can be maintained. In controller cabinets, fibre optic cables will be tied together with ty-wraps. Each cable will be labelled within 10 cm of the terminated ends with a tag and text stating the street intersection of the opposite cable end. Cables will be tagged in the controller cabinet and all other access points with "CAUTION, FIBRE OPTIC CABLE" tags. Leave enough cable slack at termination points to allow the cable to be routed through the termination hardware to a polishing/splicing table, plus a minimum of 3 meters additional slack. Cable slack will be coiled and secured with Velcro ties for breakaway protection. Cable to termination panel will be secured to cabinet with ty-wraps
- .15 If cable lubricants are necessary, ensure that they are compatible with the cable's outer sheath. Refer to the lubricant specification sheet to ensure compatibility. In all cases, avoid the use of detergent-based lubricants, as these types of lubricants promote stress cracks.
- .16 Excess cable inside pull boxes will be coiled and mechanically secured in place with Velcro straps such that the minimum bend radius is not exceeded and the cable is suspended above the pull box. The Velcro straps are to provide 'breakaway' protection in the event of an accidental dig-up between pull boxes.
- .17 Adhesive warning labels 3M – 5016 – FO type or accepted alternate will be affixed to each fibre optic cable in each access point. Access points include pull boxes and traffic signal controller cabinets. Decal strip holders, 3M – 5012 or accepted

**TRAFFIC SIGNALS**

---

alternate, will be used and will be secured in place using cable ties. Warning labels will be oriented so they are visible and are not blocked by other cables or equipment.

.18 After installation, each segment of each fibre will be tested using an Optical Time Domain Reflectometer (OTDR) and power meter equipment. Testing will be done in each direction on each fibre and at both 1310nm and 1550nm wavelengths. Launch cable will be used as per the OTDR manufacturer's specifications. Those retained to complete the work will provide a report detailing the results of each test including OTDR test results in graphical format, cable length, any fibre breaks or anomalies, attenuation of fibre's, connectors and fibre uniformity.

.19 Final testing and inspection of the cable installation will be conducted with the City on-site.

**END OF SECTION**

***Appendix A -  
Traffic Management Detail  
Specifications***

- 1.0 GENERAL**
- 1.1 Related Works .1 Traffic Regulation MMCD Section 01 55 00S.
- 1.2 References .1 WorkSafe BC, Occupational Health and Safety (OHS) Regulation, Section 18 – Traffic Control.
- .2 B.C. Ministry of Transportation (MOT) Traffic Control Manual for Work on Roadways.
- 1.3 Project Requirements .1 A Road and Sidewalk Closure Permit is required by Coquitlam for all work affecting traffic flow related to construction. A permit is required for each specific construction interference with traffic flow. A digital copy of the Road and Sidewalk Closure Permit form can be obtained for use during the contract from the City's website at [www.coquitlam.ca/closure](http://www.coquitlam.ca/closure).
- .2 A Road and Sidewalk Closure Permit form application must be submitted to the City's Traffic Operation Division 10 working days prior to start of work.
- 1.4 Measurement and Payment .1 For this Contract, payment for all work performed under this section, unless included in the Schedule of Quantities and Prices shall be treated as incidental work, including a Traffic Management Plan (TMP), Traffic Control Persons (TMP), traffic markings & all temporary traffic signs, devices as required for traffic & pedestrian safety; and all other items described in the Section 01 55 00S.
- 2.0 PRODUCTS**
- 2.1 Traffic Management Plan .1 The Contractor is required to assign a Traffic Manager for the Contract with the responsibility of preparing the Traffic Management Plan and the Traffic Control Plans, as well as the responsibility for continuing implementation of traffic control for the Work.

- .2 The Traffic Management Plan (TMP) will consist of the following components:
  - .1 Category identification through risks and project category assessment as per MOTT Traffic Management Manual for Work on Roadways
  - .2 Traffic Control Plans for individual stages of the construction
  - .3 Incident Management Plan for the response to an unplanned event and recording of incident information.
  - 4 Category 3 TMP must be signed and sealed by a qualified Professional Engineer.
  - .5 Pedestrians Management
- .3 Submission of the TMP is to be made to the *Contract Administrator* within five (5) days of the *Notice of Award* of the *Contract*, and must be approved by the *Contract Administrator* prior to start of the *Work*.
- .4 Review of the TMP will be performed by the Contract Administrator. Comments for revisions to the TMP will be returned to the *Traffic Manager* for implementations.
- .5 The Contractor shall comply with all the requirements of applicable laws, rules, regulations, codes and orders of the municipal and other appropriate authorities concerned with work on streets or highways and shall post proper notices and/or signals, and provide necessary barriers, guards, lights, flagmen or watchmen as may be necessary for proper maintenance of traffic and protection of persons and property from injury or damage. All costs involved in respect to the above requirements will be deemed to be included in the Contract Price.
- .6 The Contractor shall give due notice to local police and fire departments prior to beginning construction and shall comply in all respects with their requirements.
- .7 The Contractor, during the progress of the work, shall make adequate provision to accommodate the normal traffic along streets and highways immediately adjacent to or crossing the

work so as to cause the minimum of inconvenience to the general public.

- .8 The Contractor is required to maintain local traffic and driveway access during all stages of construction. This includes maintaining a 1.5m width walkway or pathway through the construction site for pedestrians.
- .9 Where existing streets or roads are not available as detours, all traffic shall be permitted to pass through the work with as little inconvenience and delay as possible unless otherwise provided or authorized by the Contract Administrator. If half the street only is under improvement, the other half shall be conditioned and maintained as detour.

2.2 Incident Management and Reporting

- .1 The Contractor shall facilitate incident response vehicles and staff and move traffic safely and expeditiously through or around an incident on site and provide assistance to emergency response personnel as required. An incident includes, but is not limited to, motor vehicle accidents, emergency road repairs, disabled vehicles, and debris on the road. The immediate response to an emergency shall by necessity make use of available devices and equipment.
- .2 If an incident occurs on site, the Contractor will be required to submit a report to the Contract Administrator documenting details of the incident including event, location, date, time, action taken, duration and restoration of site.

2.3 Traffic Control Plans

- .1 The Contractor shall designate a qualified Traffic Control Supervisor for the works, per the requirements of WCB regulations Section 18.  
  
The designated Traffic Control Supervisor may be the same individual that is designated as the Traffic Manager, or may be a separate individual qualified for the responsibilities of this function.
- .2 The Contractor shall prepare weekly the anticipated traffic control activities, locations, and durations for the upcoming week.

These supplementary Specifications must be read in conjunction with the Master Municipal Specifications contained in the Master Municipal Construction Documents (Platinum), Volume II, 2009.

- .3 Permissible delays shall only be considered outside Peak Hours. Permissible delays are categorized as follows:
  - a) Minor Delays - Less than two (2) minutes in duration; for occasional interruption due to construction activities. These delays shall be coordinated with available breaks in the traffic flow.
  - b) Major Delays - Maximum five (5) minutes in duration; for occasional interruption of traffic for construction activities if traffic volumes permit. These delays shall be coordinated with available breaks in the traffic flow.
- .4 The Contractor is responsible for ensuring that the flow of traffic is unimpeded by construction-related activities.

### **3.0 EXECUTION**

- 3.1 Traffic Control Plan
  - .1 A copy of the approved current Traffic Plan must be held on site by both the Site Superintendent as well as the person/company responsible for the traffic control implementation.
  - .2 Failure to produce a valid approved Traffic Plan on site, or having work not follow the Traffic Control Plan will result in immediate shut-down of the work. The Contractor will be required to safely restore facility conditions to allow traffic flow at their expense. The Contractor must take all steps to acquire an approved Traffic Control Plan before work can re-start on site. No claim will be accepted by the Owner for costs associated with this work shut-down.
- 3.2 Road and Sidewalk Closure Permits
  - .1 The Contractor must have, on-site, a copy of an approved Road and Sidewalk Closure Permit valid for the work being done. Failure to produce a valid Road and Sidewalk Closure Permit on-site will result in shut-down of the work. Failure to comply on what is stated on the approved permit will result in shut-down of the work. The Contractor will be required to safely restore facility conditions to allow traffic flow at their expense. The Contractor must take all steps to acquire a Road and Sidewalk Closure Permit before work can re-start on site. No claim will be accepted by the Owner for costs associated with this work shut-down.

---

These supplementary Specifications must be read in conjunction with the Master Municipal Specifications contained in the Master Municipal Construction Documents (Platinum), Volume II, 2009.

- |     |   |   |
|-----|---|---|
| 3.3 | Traffic Control<br>Personnel &<br>Equipment | <p>.1 The Contractor shall supply all necessary traffic control devices required to perform traffic control services for the project. Signs and traffic control devices not applying to existing conditions shall be removed. Where operations are carried out in stages, only those traffic control devices that apply to the current stage are to be left in place.</p> <p>.2 There must be sufficient Traffic Control Persons (TCPs) on site to appropriately and safely direct traffic in all sections of the Work.</p>   |
| 3.4 | Signage                                     | <p>.1 Supply, installation, maintenance and removal of all works-related signs shall be the responsibility of the Contractor. The location and type of each sign shall be indicated on the approved Traffic Control Plan, for each stage of the works.</p> <p>Traffic control signs and devices must be positioned and used as specified in the Traffic Control Plan and signs and devices must be located so as to allow traffic to move by or through the work area in a controlled manner and, if necessary, to come to a controlled stop with due regard for the prevailing weather and road conditions.</p> <p>Signs shall be checked daily for legibility, damage, suitability and location. Signs and delineators shall be cleaned as frequently as necessary to ensure full legibility and reflectance.</p> |
| 3.5 | Detours                                     | <p>.1 Any proposed detours must be approved by the Contract Administrator and conducted in accordance with the approved Traffic Plan and the Traffic Control Manual for Work on Roadways.</p>   |
| 3.6 | Abrupt Changes in<br>Surface Elevations     | <p>.1 The Contractor shall minimize any abrupt changes in roadway elevation left exposed to traffic during both working and non-working hours.</p> <p>A wedge of asphalt must be used as a transition to vertical differences in travelled areas and have a slope of 4:1 or less.</p>   |
| 3.7 | Cyclist and Pedestrian<br>Access            | <p>.1 The Contractor shall make provision for pedestrians, wheel chairs and bicycles to have safe access across the work zone at</p>  |

---

These supplementary Specifications must be read in conjunction with the Master Municipal Specifications contained in the Master Municipal Construction Documents (Platinum), Volume II, 2009.

all times. If this cannot be readily accommodated, then acceptable detours and appropriate signs shall be provided.

3.8 Temporary Pavement Markings

- .1 The Contractor shall be responsible for the application and removal of all temporary pavement markings and reflective devices.

All temporary markings must be removed after installation of permanent markings.

**4.0 TRAFFIC RESTRICTIONS**

4.1 Road and Sidewalk Closure Permits

- .1 Minimum of Single Lane Traffic in each direction and all local traffic must be accommodated at all times. Refer to Road Specific Considerations, Clause 6.2.

- .2 A City of Coquitlam Road and Sidewalk Closure Permit is required for each instance of closure and will be valid for a maximum period of one (1) week and, if still necessary, re-submittal of a Road and Sidewalk Closure Request is required.

A copy of the approved Road and Sidewalk Closure and Lane Closure Permit must be held on site by both the Site Superintendent and the person/company responsible for the traffic control implementation.

- .3 Total Road Closure is Not Permitted**

- .4 Detours will only be permitted as approved by the Contract Administrator and must have a complete Traffic Control Plan indicating detour route, signing, and duration. Detours will not be allowed without sufficient lead time for commercial and retail operation to react appropriately to detour information provided to them.

4.2 Lane Closure Restrictions

- .1 **For each of the road sections affected:**
- Road and Sidewalk Closures will be reviewed for appropriateness during the allowable hours of work.
  - Access to properties to be maintained

These supplementary Specifications must be read in conjunction with the Master Municipal Specifications contained in the Master Municipal Construction Documents (Platinum), Volume II, 2009.

- Sufficient Traffic Control Persons are required for each Road and Sidewalk Closure (or any work activities), including side street intersections, to safely guide traffic through the work site.

**5.0 HOURS OF WORK**

.1 **The hours of work shall be from 0700h to 1900h inclusive Monday to Friday and 0900h to 1800h inclusive Saturdays, unless noted otherwise.**

.2 Some allowances may be made for paving operations, depending on a proposal acceptable to the Contract Administrator.

.3 Line Marking work may be performed at night, (21:00 to 05:00).

No work is allowed on Sundays without specific written permission from Contract Administrator.

**6.0 CONSTRUCTION OPERATIONS**

6.1 Truck Routes

.1 The Contractor is restricted to the City's designated Truck Routes. The current Truck Route Map is available on the City's website at [www.coquitlam.ca](http://www.coquitlam.ca) and can be found under **Residents, Transit & Transportation, Trucking Routes.**

6.2 Road Specific Considerations

.1 Ensure that Traffic Management Plan accommodates businesses and residences during construction activities.

.2 Contractor shall not schedule paving during garbage pick up day.

.3 **Any construction activity requiring closure of two or more lanes shall be carried out during night time only (from 8pm to 6am).**

.4 All travel lanes must be open to all traffic at the end of working hours.

.5 Contractor must follow all the specifications and restrictions as shown in the table below:

---

These supplementary Specifications must be read in conjunction with the Master Municipal Specifications contained in the Master Municipal Construction Documents (Platinum), Volume II, 2009.

LOCATION	ALLOWABLE TIME (Includes Set up and Take Down Time)		COMMENTS
Lougheed Highway East Bound	Monday to Friday	7:00am to 3:00pm	No lane closure allowed between 3:00pm and 6:00pm  Two of the three lanes on Lougheed Highway should always remain open
Lougheed Highway West Bound	Monday to Friday	9:00am to 5:00pm	No lane closure allowed earlier than 9:00am  Two of the three lanes on Lougheed Highway should always remain open
Clarke Avenue North Bound	Monday to Friday	7:00am to 3:00pm	No lane closure allowed between 3:00pm and 6:00pm  One lane to be maintained during construction at other times
Clarke Avenue South Bound	Monday to Friday	9:00am to 5:00pm	No lane closure allowed earlier than 9:00am  One lane to be maintained during construction at other times

6.3 Work Stoppage Due to Traffic

- .1 The City will not control or direct traffic control activities of the Contractor, but may require an immediate stop to any work where, in the sole opinion of the Contract Administrator, the provided traffic management plan is ineffective or creating unreasonable delays.

These supplementary Specifications must be read in conjunction with the Master Municipal Specifications contained in the Master Municipal Construction Documents (Platinum), Volume II, 2009.

- 6.4 Construction Activity and Signage .1 The Contractor will be responsible to place other construction information signs as required to inform the public of construction activities, and ensure safe travel through the work site.
- 6.5 Construction Zone Information Signs .1 The Contractor is required to provide, one week prior to start of work, **four** stationary signs at each intersection, one in each direction, to inform traffic of existing and anticipated conditions at entry points of the lane to be worked on, locations for these signs will be provided by the Contract Administrator. Signs to be re-used and transferred to the next location once lane is completed.
- Ensure that signs and locations are addressed in the Traffic Management Plan. All signs are to be removed at the end of the construction period.
- Exact locations to be determined on site by Contract Administrator.
- Construction Zone Information Signs to follow specifications below. Description of work and street location to be changed for each location as approved by Contractor Administrator:
- 6.6 Changeable Message Sign Boards The following locations will require Changeable Message Signs (CMS) for the duration of the project. CMS boards must be able to handle a minimum of 3 lines per page/screen and must be in service at least 5 normal work days prior to construction start.
- Eastbound – Lougheed Highway, East of King Edward Street
  - Westbound – Lougheed Highway, West of Woolridge Street

These supplementary Specifications must be read in conjunction with the Master Municipal Specifications contained in the Master Municipal Construction Documents (Platinum), Volume II, 2009.

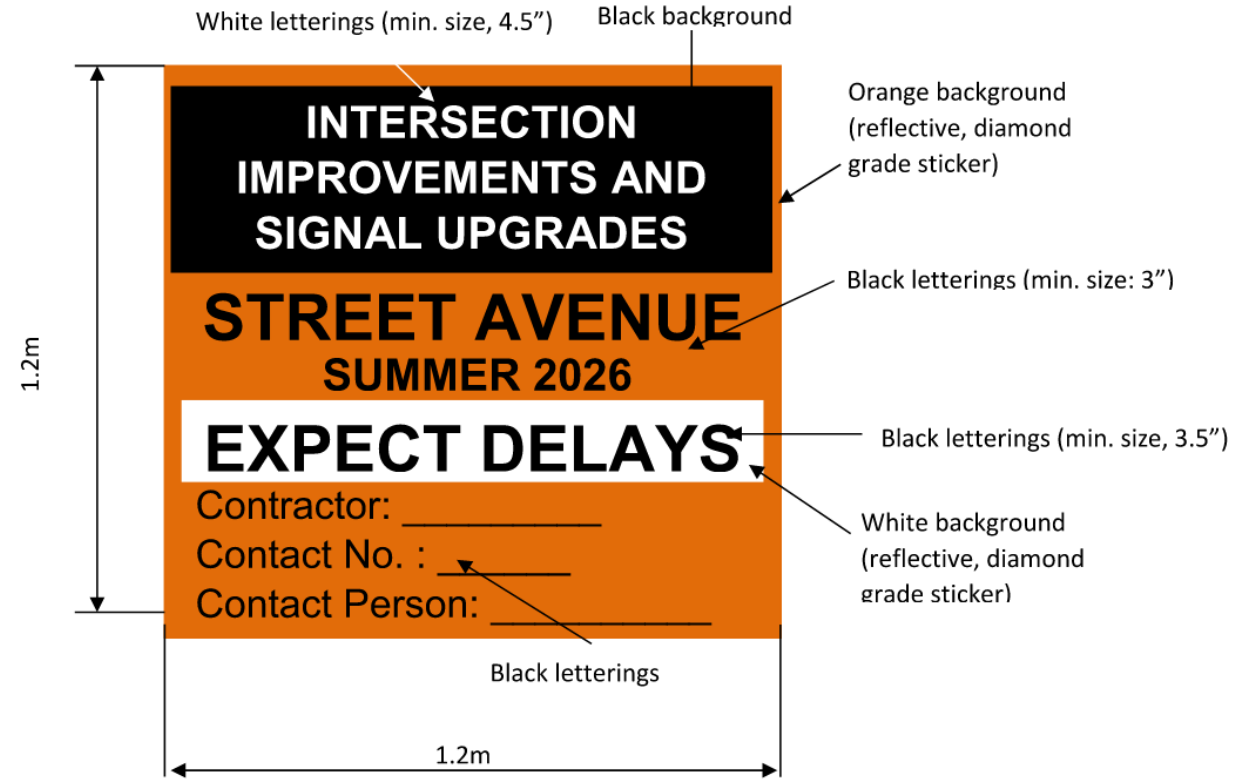

These supplementary Specifications must be read in conjunction with the Master Municipal Specifications contained in the Master Municipal Construction Documents (Platinum), Volume II, 2009.

APPENDIX 1



City of Coquitlam  
Road and Sidewalk  
Closure Permit Request

Traffic and Street Use Management Section  
3000 Guildford Way, Coquitlam BC V3B 7N2  
Phone: [604-927-6250](tel:604-927-6250) Email: [StreetPermits@coquitlam.ca](mailto:StreetPermits@coquitlam.ca)

~~Initial Permit: \$450~~ ~~Renewal Permit: \$75~~

Application Date: \_\_\_\_\_ City Project or Film Permit Number (if applicable): 79058

- An Initial Permit is required for all new applications and when the location, type of work, or the type of traffic controls change from what was approved for the Initial Permit. The application needs to be received a minimum of 10 business days prior to the intended closure date.
- A Renewal Permit extends the rights and privileges of the approved Initial Permit and is required when the timeline needs to be extended. The application must be received a minimum of 5 business days prior to the intended extension date.

Development Site Address (if applicable): \_\_\_\_\_

Work location (street name, block number, to/from, at, etc.) \_\_\_\_\_

**Contact Information**

Applicant Company Name: \_\_\_\_\_

Applicant (person completing application form)

Name: \_\_\_\_\_ Title: \_\_\_\_\_

Phone: \_\_\_\_\_ Email: \_\_\_\_\_

Applicant's Signature: \_\_\_\_\_

Company Name (Prime Contractor): \_\_\_\_\_

Site Superintendent

Name: \_\_\_\_\_ Title: \_\_\_\_\_

Phone: \_\_\_\_\_ Mobile: \_\_\_\_\_ Email: \_\_\_\_\_

**Permit Information**

Start Date: \_\_\_\_\_ End Date: \_\_\_\_\_

Day(s) and Time(s):  Monday  Tuesday  Wednesday  Thursday  Friday From: 00:00 To: 00:00  
 Saturday From: 00:00 To: 00:00  Sunday From: 00:00 To: 00:00

Specific Lanes:  Curb  Inside/Centre Lane  Left Turn Lane  Right Turn Lane  Parking Lane  
 All Lanes  Sidewalk/MUP  Bicycle Lane

Direction:  Northbound  Southbound  Westbound  Eastbound

Purpose of Work:  Concrete Pour  Utility Installation  Curb Installation  Other \_\_\_\_\_

This permit is related to:  City Design and Construction  City Parks  External Environmental  
 Development  External/Utilities

City Contact (if applicable): \_\_\_\_\_

**Office Use Only**

Permit Conditions/Comments:

Approved by \_\_\_\_\_

Date \_\_\_\_\_

### Application Checklist



The following information must be provided. Incomplete applications will not be reviewed.

1.  Traffic Management Plan (TMP); **OR**  
 Traffic Management Manual for Work on Roadways Figure Number: \_\_\_\_\_
2.  **Project Category Determination** (per [2020 Traffic Manual for Work on Roadways](#)).  
 Initial Project Category Assessment  
 Project Risk Analysis  
 Category 1  Category 2  Category 3
3.  **Prime Contractor Designation Letter**
4.  **City of Coquitlam Certificate of Insurance**
5.  **Notification Letter and Map** (required for all full road closures). A Notification Letter must be provided to all affected residents and businesses.  
 Yes  No  Not Applicable
6.  **Traffic Control Persons** (flag persons) **required?** All operations within the road right-of-way must comply with WorkSafe BC regulations and BC Ministry of Transportation standards for work on roadways.  
 Yes  No If yes, how many? \_\_\_\_\_
7.  **Bus routes/stops impacted?** Applicant is to contact Coast Mountain Bus Company (with a minimum of 3 days' notice) [Temporary Transit Changes Request Form](#). General information can be found by visiting [Temporary Transit Changes](#).
8.  **City of Coquitlam Solid Waste has been contacted?** Coquitlam Environmental Services contacted regarding impact to garbage/recycling routes and pick up Phone: [604-927-4300](tel:604-927-4300) Email: [wastereduction@coquitlam.ca](mailto:wastereduction@coquitlam.ca)  
 Yes  No  
Are operations impacted?  Yes  No  
If Yes:
  - a plan to ensure continuous collection has been provided:  Yes  No
  - Day(s) of the week impacted: \_\_\_\_\_
  - Time(s) of the day impacted:  a.m.  p.m.
9.  **Pedestrian / Bike Lanes impacted?** Please describe sidewalks and/or bicycle facilities that will be impacted by the proposed work.  
\_\_\_\_\_  
\_\_\_\_\_
10.  **Is the work on, or will it impact a road along our [Major Road Network](#)?**  
 Yes  No

### Additional information

- Only vehicles actively engaged in the performance of cleaning, clearing, maintenance, repair, construction or other work are permitted within work zones. Vehicles being used by Superintendents, Traffic Control Persons, and other construction personnel that are not actively engaged in work described above are not permitted within the work zone and are not permitted parking /stopping prohibitions.
- Closures of sidewalks, cycling facilities, lanes, and full road closures are only permitted during the time periods indicated on the approved permit. Traffic controls are not permitted outside of these approved permit hours.

These supplementary Specifications must be read in conjunction with the Master Municipal Specifications contained in the Master Municipal Construction Documents (Platinum), Volume II, 2009.

***Appendix B -  
Archaeological Chance Find  
Procedures***

# Archaeological Chance Find Procedures City of Coquitlam

DRAFT 2

November 2021 (version 2)



## Table of Contents

Introduction.....	3
Purpose .....	3
Archaeological Sites in British Columbia .....	4
HCA Legislation and Policies .....	4
First Nation Cultural Heritage Management.....	4
Potential to Encounter Archaeological Sites .....	6
Types of Archaeological Sites.....	6
Archaeological Chance Find Procedure.....	6
Archaeological Chance Find Procedure - Suspected Ancestral (Human) Remains.....	7
Management Options .....	7
Best Practices for CFP Implementation .....	8
Contact List .....	10
Archaeological Site and Materials Identification .....	10
Artifacts .....	10
Beads .....	12
Indigenous Historical Artifacts.....	12
Hearths .....	13
Fire-Altered Rock .....	13
Shell and Non-Shell Midden .....	14
Surface Features .....	15
Rock Shelters and Caves .....	15
Ancestral (Human) Remains.....	15
Petroglyphs and Pictographs (Rock Art).....	16
Fish Weirs and Traps .....	17
Wet Sites.....	17
Culturally Modified Trees (CMTs) .....	18
Additional Resources .....	19
References Cited .....	19

## Introduction

This document is presented as an accompaniment to Kwikwetlem Cultural Heritage and Archaeology Chance Find Procedures training provided by Brown & Oakes Archaeology to City of Coquitlam (or the “City”) staff and contractors.

The Chance Find Procedure (CFP) is intended to provide City planners and onsite project personnel guidelines for the appropriate response to an unanticipated discovery of known or suspected archaeological or cultural heritage materials during City operations. A CFP is NOT a substitute for professional archaeological assessment of project areas considered to hold archaeological potential. Thorough archaeological assessment will always reduce project risk of harms to protected archaeological sites and minimize the potential for encountering unanticipated material. This CFP training is intended to promote the preservation and proper management of heritage resources that are unexpectedly encountered during City activities.

The document presents a summary of archaeology site protection legislation, steps to follow in the case of suspected or observed archaeological materials, a list of appropriate authorities to contact in the case of archaeological site encounters, and a guide to archaeological site and materials recognition. Information on Kwikwetlem culture history and connections to traditional lands is not presented in this document and this information is best shared via virtual or in-person presentations.

## Purpose

The purpose of CFP documentation is to aid in the protection and proper management of archaeological materials encountered during City of Coquitlam activities. Many land-altering activities have the potential to expose and/or negatively impact undocumented archaeological materials.

The purpose of this document is to:

- Ensure project personnel are aware that undocumented archaeological sites are likely to be present in the City of Coquitlam.
- Promote awareness of activities that may lead to the exposure of archaeological materials, including excavations, vegetation clearing, field survey and inspections, and more.
- Provide personnel the appropriate steps to follow if suspected or observed archaeological resources are encountered during work or personal activities.
- Provide education and resources to assist recognition of archaeological site types and materials in the lower Fraser River region.

## Archaeological Sites in British Columbia

Archaeological sites are places that exhibit physical evidence of past human activity. Archaeological sites in British Columbia are automatically protected under the *Heritage Conservation Act* (HCA) when located on provincial, crown, municipal, or private land<sup>1</sup>. The vast majority of archaeological sites in BC include places and belongings of Indigenous peoples. Some post-1846 sites related to newcomer history may also be registered and protected under the HCA if of significance to a place, industry, or region, for example. HCA protection is extended to ship and plane wrecks more than 2 years old.

Many First Nations consider the widely accepted definition of an archaeological site as a place featuring only the material remains of human activity too restrictive and instead advocate for the recognition and protection of a wider range of “cultural heritage” site types, including places of spiritual significance, named locales, known travel routes, and other places of cultural value.

The majority of the City of Coquitlam has not been surveyed for archaeological sites and it is reasonable to expect that many archaeological sites are buried and/or undetected. These sites are collectively referred to as undocumented archaeological sites.

## HCA Legislation and Policies

Archaeological sites are automatically protected under the terms of the *Heritage Conservation Act* whether known or undocumented. Sites are protected whether previously disturbed by historic activities or intact. The HCA prohibits the alteration or disturbance of archaeological sites in whole or in part, on provincial public and private lands, whether impacts are intentional or inadvertent, and irrespective of previous land disturbance.

The HCA provides substantial penalties for the destruction or unauthorized disturbance of archaeological sites including imprisonment for up to two years and fines of up to \$1,000,000.

Alterations to archaeological sites may proceed under appropriate HCA permits held by professional archaeologists following provincial assessment guidelines<sup>2</sup>. Work plans and methodologies related to archaeological site investigations must meet provincial regulatory standards and are expected to conform to participating First Nation cultural heritage policies and best-practice standards.

Archaeological materials on federally managed lands may be protected by other legislation and policies. Many federal agencies will adhere to the requirements outlined in the *HCA* when managing archaeological sites.

---

<sup>1</sup> <http://www.for.gov.bc.ca/archaeology/index.htm>.

<sup>2</sup> The HCA is administered by the Archaeology Branch, Ministry of Forests, Lands, Natural Resources and Rural Development.

## First Nation Cultural Heritage Management

Many BC First Nations maintain cultural heritage policies and/or heritage permitting systems to assert oversight over Indigenous cultural heritage management and to ensure a high standard of archaeological practice. Contact should be made with locally affected Nations prior to any heritage study or project work with the potential to encounter cultural heritage materials to ensure adherence to Nation-preferred heritage protections, permits, and policy.

## Potential to Encounter Archaeological Sites

Any project involving ground alterations has the potential to expose undocumented archaeological sites. Common forms of ground disturbances that have led to site discoveries include land grading, vegetation clearing/grubbing, excavation, asphalt/concrete removal, geotechnical drilling, access road or trail building, foundation demolition, heavy equipment movement, habitat planting, stream and pond channeling or dredging.

Other kinds of work activities where teams may encounter undocumented archaeological sites include field teams working in proximity to natural, undeveloped or minimally disturbed terrain. Teams involved in field surveys, field inspections, or inventories of natural ground and waterways, riparian areas, municipal parks and trails, forested areas, cut bank or erosion area, and so on may encounter exposed archaeological materials.

City workers or contractors engaged in any activity that may result in archaeological materials identification should be made aware of HCA site protection legislation and field supervisors properly versed CFP procedures.

## Types of Archaeological Sites

The following site types are well-known across the lower Fraser River region and may be encountered in the City of Coquitlam. The following site types may contain a range of artifact types and sediment signatures.

- **Stone tool sites** containing isolated artifacts or accumulations of stone tool working debris.
- **Habitation sites** show accumulations of food remains, tools, and evidence such as hearths indicating short term and seasonal camps and settlements used for travel and resource procurement as well as large and permanent villages.
- **Surface features** such as cultural depressions created by former habitations, earthen fortifications, burial mounds, and rock cairns.
- **Wet sites** contain preserved organic materials like woven basketry or wood tools in addition to other cultural material; these sites form under special preservation conditions typically anaerobic water saturated sediments along waterways and floodplains.
- **Culturally Modified Trees (CMTs)** include bark stripped trees, planks, and territory markers.
- **Rock art** including pictographs (painted rock images) and petroglyphs (images carved or pecked into rockfaces or boulders).

## Archaeological Chance Find Procedure

In the event of found or suspected archaeological material, follow the procedures outlined below.

### **STEP 1: WATCH** for potential archaeological materials

- ⇒ Know that undocumented archaeological sites are expected throughout Coquitlam.
- ⇒ Know that archaeological materials are protected by law and must be reported.
- ⇒ If you believe you may have encountered archaeological materials (either intact or disturbed) follow the steps outlined below.

### **STEP 2: STOP** work in proximity to the material

- ⇒ If known or suspected archaeological materials are encountered, STOP work in the immediate vicinity.
- ⇒ Do not disturb, move, relocate, or collect the material.

### **STEP 3: REPORT** observed materials

- ⇒ Alert the site supervisor that suspected archaeological materials have been observed.
- ⇒ The site supervisor will ensure appropriate contact is made with City managers who will in turn reach out to archaeological professionals.

### **STEP 4: CONTACT** archaeological professionals

- ⇒ Seek immediate advice from an archaeological professional.
- ⇒ Teams may be advised to protect the area with flagging or cones until the area can be assessed by the appropriate representative.
- ⇒ Teams may be requested to provide locational details or photographs of the material.

### **STEP 5: AWAIT** advisement

- ⇒ Wait for instructions from the appropriate representative; do not begin ground disturbing work until cleared to do so.
- ⇒ Prepare and submit an incident report to ensure compliance with appropriate regulators and interest groups.

## Archaeological Chance Find Procedure - Suspected Ancestral (Human) Remains

In the event of found or suspected human remains, follow the procedures outlined below\*.

**STEP 1: STOP** all activity at the job site immediately, including the removal of backfill. Do not rebury the remains.

**STEP 2: REPORT** to the City Project Manager. The Project Manager will contact an archaeological professional and determine the appropriate course of action. In most cases, the archaeology professional will visit the site to determine if the materials are reasonably expected to be human and archaeological. If warranted, the consultant will notify the Archaeology Branch and the RCMP, the Office of the Coroner, and affected First Nations. The Coroner will affirm whether the remains are archaeological and not of forensic concern. The archaeologist will inform the Archaeology Branch and First Nations will be consulted to determine culturally appropriate handling protocols and subsequent project management options.

**STEP 3: PROTECT** the affected location with flagging or cones to prevent additional disturbance and for privacy. Do not photograph the material.

**STEP 4: TREAT** the remains with dignity and respect. Do not allow bystanders to take photographs or video.

**STEP 5: AWAIT** advisement.

\* If it is reasonable to think the human remains are not archaeological but forensic in nature, an immediate call to the RCMP is required.

### Management Options

If determined that an archaeological or cultural heritage site (intact or disturbed) is present, an archaeologist will coordinate communications with the City, local affected First Nations, and the Archaeology Branch to evaluate management options. Archaeology Branch and First Nations approval and additional permitting may be required prior to the implementation of management options.

Examples of potential management options are provided below. Options will vary based on site characteristics, proponent needs, and Archaeology Branch and First Nation requirements.

**Option A:** Site avoidance through project redesign or relocation. Site avoidance is always preferred. Avoidance minimizes impacts to irreplaceable archaeological sites and reduces cost and schedule impacts.

**Option B:** Systematic data recovery through controlled archaeological excavation or other method. Data recovery is destructive to archaeological sites and will entail consideration of costs and schedule coordination.

**Option C:** Monitoring of construction activities by a professional archaeological team. Monitoring is appropriate where project impacts cannot be evaluated before construction (due to impenetrable surfaces or underground facilities, for example) or where potential to encounter archaeological materials is present following impact assessment or systematic data recovery.

## Best Practices for CFP Implementation

- A Chance Find Procedure is best applied as an outcome stemming from archaeological assessment – as a last step verification that archaeological materials have not been overlooked in project area assessments, or where there is a professional assessment that documents a low expectation for encountering archaeological materials in a work area.
- A Chance Find Procedure is not an acceptable replacement for a professional archaeological overview (AOA) or archaeological impact assessment (AIA) or a well-designed and implemented archaeological construction monitoring plan for many areas. Engagement with professional archaeological teams, affected First Nations, or the Archaeology Branch will assist in appropriate heritage study approaches.
- Chance Find Procedure training must be delivered by professional archaeologists and local area First Nations who wish to contribute to CFP presentations.
- Chance Find Procedures should be summarized regularly as part of job or project requirements, and CFP training repeated by the archaeological and First Nation team for new employees, project teams, and subcontractors.
- Chance Find Procedures do not supersede any requirements or policies pertaining to cultural heritage management by First Nations with interests in the area. Proponents are encouraged to seek input from interested First Nations on area-specific CFPs as part of any project engagement process.

## Contact List

### Archaeology Branch

Paula Thorogood	Planning and Assessment Manager	250-953-3300	<a href="mailto:Paula.Thorogood@gov.bc.ca">Paula.Thorogood@gov.bc.ca</a>
Nathan Friesen	Planning and Assessment Supervisor	250-953-3306	<a href="mailto:Nathan.P.Friesen@gov.bc.ca">Nathan.P.Friesen@gov.bc.ca</a>

### City of Coquitlam

Main Reception 604-927-3000

### Police and Coroner

RCMP (Non-emergency)	Coquitlam	604-945-1550
BC Coroners Service	Lower Mainland Region	604-660-7708

### Area First Nations

Kwikwetlem First Nation 604-540-0680

Katzie First Nation 604-465-8961

Kwantlen Nation 604-888-2488

Musqueam Indian Band 604-263-3261

Stó:lō Nation 604-824-2420

Tsleil Waututh Nation 604-929-3454

## Archaeological Site and Materials Identification

The following archaeological sites and artifacts are common to the lower Fraser River region. This guide is to assist in the recognition and protection of archaeological materials found by chance. If you identify any archaeological material, stop work immediately and contact a professional archaeologist.

### Artifacts

Artifacts are objects made or modified by humans and may be formed of stone, bone, antler or wood. Bone, antler and wood tools were produced in abundance, but stone artifacts are the most common artifacts found in the lower Fraser region because of the preservation durability of stone. Bone and antler were fashioned into a variety of items, including needles, knives, points, jewelry, awls and scrapers. Wood was used to make implements like spoons and bowls, handles, ceremonial objects, canoes, houses, and much more.



Photo Credit: RBCM, Archaeology Collection. Antler and wood tools (<https://learning.royalbcmuseum.bc.ca>)

Stone tools common to this region include projectile points, knives, adzes (axes), scrapers, mauls (hammers), net weights, beads, and more. Archaeologists distinguish chipped stone from ground stone artifacts, each distinguished by the mode of manufacture, either flaking scars or grinding and polishing marks. Stone flakes or 'debitage' is produced during the process of making stone tools. These flakes were sometimes used as tools themselves or were left behind at the stone tool working site. Culturally produced debitage shows features distinctive from naturally broken rock, gravel or crush, but these signatures can be difficult to identify to an untrained eye. Stone artifacts were produced from dacite, quartzite, slate and nephrite as well as obsidian, chert, and other materials. Stone was acquired locally or transported or traded over long distances; high-quality materials like obsidian has been traced to locations from Prince Rupert to Oregon and beyond.

Artifacts may be found as isolated finds or in association with other cultural materials.

Archaeological Chance Find Procedure



Photo Credit: B&OA, Chipped stone artifacts from Coquitlam Lake.



Photo Credit (left): B&OA, Nephrite ground stone adze from Port Coquitlam. Photo Credit (right): RBCM, Archaeology Collection. Ground stone hand mauls (<https://learning.royalbcmuseum.bc.ca>)

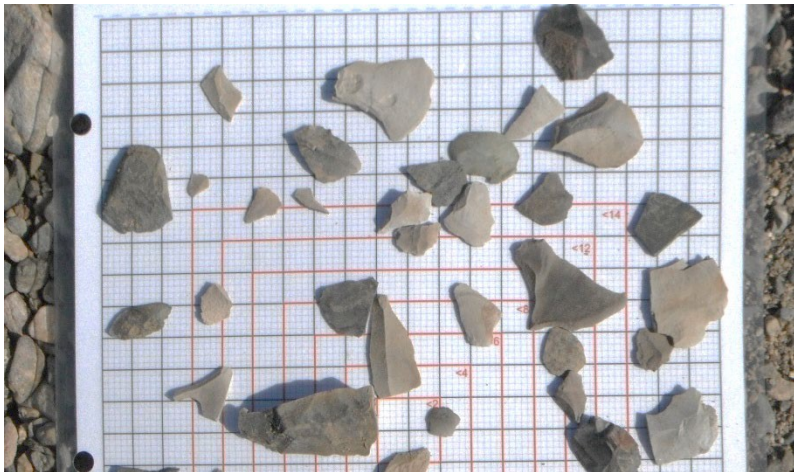

Photo Credit: B&OA, Stone tool debitage from BC Interior.

## Beads

Beads were made from a variety of materials including stone, shell, bone and glass (in more recent times). Shell and stone disc beads were used in jewelry, regalia and in mortuary practices across the Northwest Coast. On the Lower Fraser it is most common to find stone beads at archaeological sites fashioned from mud or silt stone, slate, or other softer stone. At some burial sites, individuals of rank were laid to rest with thousands of stone and shell beads.



Photo Credit: B&OA, Ground stone beads from near Agassiz.

## Indigenous Historical Artifacts

Indigenous use of European materials in the years following contact are often found in early historic sites. Ceramics, glass, and metal were valued for their strength, durability, ease of access, or aesthetic properties. Glass was worked using traditional stone tool techniques in the same way as obsidian (a natural volcanic glass). Clay pipes were adopted by Indigenous peoples who several centuries earlier had introduced the practice of tobacco smoking to European traders. Glass beads were used by European fur traders to trade with Indigenous peoples; trade beads were initially valued for their vibrant colour and the expectation of beads as a wealth item.

Photo Credit (left): B&OA, Worked glass and clay stone pipe, Coquitlam.



Photo Credit (middle): <https://www.canadashistory.ca/explore/fur-trade/tobacco-pipes>. Photo Credit: Oregon Museum of Natural and Cultural History, Glass trade beads (<https://mnch.uoregon.edu/index.php/collections-galleries>).

## Hearths

Hearths are the remnants of fires identifiable by dense black charcoal, ash and heat oxidized sediments. While natural forest fires may also leave traces of burning, hearths tend to be more defined and frequently show concave bases, evidence of repeated use, and contain or are in proximity to burned bone, fire-altered rock, and artifacts.

## Fire-Altered Rock

Fire-altered rock (FAR) is rock modified by repeated heating and cooling. Heating small, rounded river cobbles and immersing the hot stones in water filled baskets or boxes was a frequently used cooking technique called 'stone boiling'. Heated stones were also used to warm clothing and bedding. The repeated heating and cooling of FAR created distinctive fracture and colour patterns that are easily distinguished from naturally broken rock. FAR shows irregular breakage patterns, is frequently deeply pitted, is often deep rust or black in colour, and may be found mixed in charcoal and ash laden sediments. As FAR is often found in abundance around settlement areas or near cooking features and hearths, it is a frequent first indicator of the presence of archaeological sites. Often mixed in FAR deposits are boiling stones—small, rounded pebbles that have not yet been fractured by thermal processes



Photo Credit: B&OA, Fire altered rock, Coquitlam.



## Shell and Non-Shell Midden

Midden deposits are generally indicative of camp or village sites. Middens accumulate through the repeated, ongoing use of an area where food remnants or the debris of daily living build up in layers at a site over time. In coastal areas, shellfish provided an abundant food source and, middens contain abundant fragmented or whole shell typically embedded in dark, greasy, sediments rich in charcoal, ash, fire cracked rock, burnt materials, and artifacts. Because shell neutralizes the acidity in soil, shell middens enhance preservation of organic food remains and tools, and fish and mammal bone, wood, antler, and botanical remains are often well-preserved in shell midden sites.

Non-shell middens are accumulations of living materials formed at camps and settlements away from marine waterways. Non-shell midden shows layered deposits of dark sediments, ash, and sometimes sand and clay in sediments with little to no shell. These deposits rarely contain bone, antler, or wood remains due to poorer preservation environments.

In Coquitlam, non-shell middens are the more common site type but there are a few examples of inland shell midden sites associated with camps or settlements where shellfish was transported to locations by travel or trade.



Photo Credit (left): B&OA, Non-shell stratified midden Port Coquitlam. Photo Credit (right): Shell midden, Vancouver Island (<https://learning.royalbcmuseum.bc.ca/pathways/can->)

## Surface Features

Surface features are non-portable cultural formations visible on the landscape. Features may include pits or depressions, earthen mounds or rock cairns, petroforms (rock arrangements) or trails. Cultural depressions may indicate the location of semi-subterranean winter dwellings, plank houses where midden accumulated around the outside of structures, cache pits used for tool or food storage, or pits and trenches used for food cooking or processing. Cultural depressions are identifiable by their uniform shape (usually round or rectangular), a berm may be present around the edge of features, the presence of associated artifacts, or concentrations of charcoal, ash, and fire altered rock.

Cultural mounds or rock cairns are other familiar surface features. Earthen burial mounds and rock cairns are part of a mortuary tradition found throughout the lower Fraser region over the past 1,500 years. Cultural mounds and cairns range in size from around a meter in diameter to more than 12 meters across. Individual occurrences or clusters of well-formed oval or circular mounds of earth and rock should trigger archaeological assessment.



Photo Credit: SFU Museum, Winter pit house village, Lillooet.

## Rock Shelters and Caves

Rock shelters were used, among other purposes, as camps, spiritual or burial locations, and storage caches. Shelters can be found associated with overhangs of large boulders, indentations in rock bluffs or in caves. Shelters often associate with artifacts, rock art, and hearth features.

## Ancestral (Human) Remains

Human remains are especially sensitive and significant finds. Any potential human bone requires immediate implementation of the CFP. Ancestral remains are frequently present at archaeological locations and may be found articulated in a burial context or as scattered fragments.

## Petroglyphs and Pictographs (Rock Art)

Northwest Coast rock art includes images depicted on boulders, rock overhangs, rock faces, or other exposed rock surfaces. Pictographs are drawings or designs painted on rock using pigments like ochre or charcoal mixed with grease. Petroglyphs are images incised or pecked into stone. Designs vary widely and often depict animals, humans, or an extensive variety of geometric shapes.



Photo Credit: B&OA, Portion of petroglyph panel at Petroglyph Provincial Park, Nanaimo.



Photo Credit: B&OA, Portion of pictograph panel at Pitt Lake.

## Fish Weirs and Traps

Fish weirs are structures constructed to funnel and trap fish for harvesting. Traps were built in intertidal areas along marine and river shorelines and near stream mouths. Weirs vary in form and structure depending on water and shoreline conditions, fish species targeted for harvest, intended volume of harvest, and community preferences. Fish weir sites are identifiable by linear or patterned arrangements of wooden stakes protruding from beach or bank edges or boulder alignments along waterways.



Photo Credit: Washington State Archives, Yelm Jim Fish Trap 1885  
<http://www.digitalarchives.wa.gov/Record/View/DAA73FC7A57E989D65B6DBEA419FC89E>

## Wet Sites

Wet sites are special preservation environments that form in low oxygen water saturated environments along waterways, in bogs and on floodplains. These locations permit enhanced preservation of organic artifacts like wood, bark, and botanicals. Artifacts found in wet sites have included basketry, twine and rope, wooden tools and weapons, architectural structures, and ceremonial implements made of wood and bone.



Photo Credit (left): Mike Blake. Ground slate knife with wooden handle, Agassiz. Photo Credit (right): Katherine Bernick, Waterlogged and preserved basket, Coquitlam.

## Culturally Modified Trees (CMTs)

Culturally Modified Trees are trees that have been utilized by Indigenous Peoples for a broad range of cultural uses. Wood was used to build houses, canoes, tools, and weapons. Branches, boughs, and leaves were used to fashion tools, for medicine and in cultural ceremony. Harvesting cedar bark and roots was undertaken regularly to make clothing, cordage, basketry, and sleeping mats, ceremonial regalia, and much more.

Triangular bark stripped cedars are the most common form of CMT; a long, linear triangular bark scar will show where bark was removed from the trunk of a living tree. The exposed scar will heal over time creating a seam on the outer tree bark. This form of sustainable harvesting allowed the same tree to be used multiple times for bark harvesting. CMTs can also show evidence of wood removal where wedges were used to pry rectangular planks of wood from standing, living trees.

Logging and clearing throughout much of Coquitlam municipality reduces the chance that archaeological CMTs remain in most forested areas today, but more recent CMTs where bark or wood was harvested from second-growth forest by Kwikwetlem for cultural uses may be present.



Photo Credit: B&OA, Bark stripped cedars, Coquitlam.

## **Additional Resources**

Learning Portal, Royal BC Museum - <https://learning.royalbcmuseum.bc.ca>

SFU Museum of Archaeology & Ethnology - <https://www.sfu.ca/archaeology/museum.html>

## **References Cited**

Archaeology Branch (1999). Found Human Remains. On file with the Archaeology Branch, Victoria, BC. From [http://www.tca.gov.bc.ca/archaeology/policies/found\\_human\\_remains.htm](http://www.tca.gov.bc.ca/archaeology/policies/found_human_remains.htm)

Archaeology Branch (2010). Heritage Conservation Act (RSBC 1996). On file with the Ministry of Tourism, Culture, and the Arts, Victoria, BC. From

***Appendix C -  
As-built Records***

# ***As-built Records:***

As built record drawings for City of Coquitlam are available in QtheMap, the City of Coquitlam's online interactive map: <http://coquitlam.ca/QtheMap>. It can be searched using the magnifying glass at the bottom of the screen.

As-built Records can also be provided to Bidders on as per request basis. Bidders can e-mail [bid@coquitlam.ca](mailto:bid@coquitlam.ca) to request the files. All requests for files will be sent the next business day in order to consolidate requests.

Files include the following:

## Clarke and Glenayre:

D0150-11	D0400-04
D0400-05	D0483
E0077-02	E0077-03
E0077-04	E0512-01
S0304	S0472
W0683-02	W0683-03

## Lougheed and Woolridge:

C0078-02	C2045-02
D2122	D2247
D2685-03	E1229-01TS
E1229-02TS	H0010-08
R0046-03	R0240-04
S0360-01PS	S0360-02PE
W0458	W3230-02

***Appendix D -  
Standard Detail Drawings***

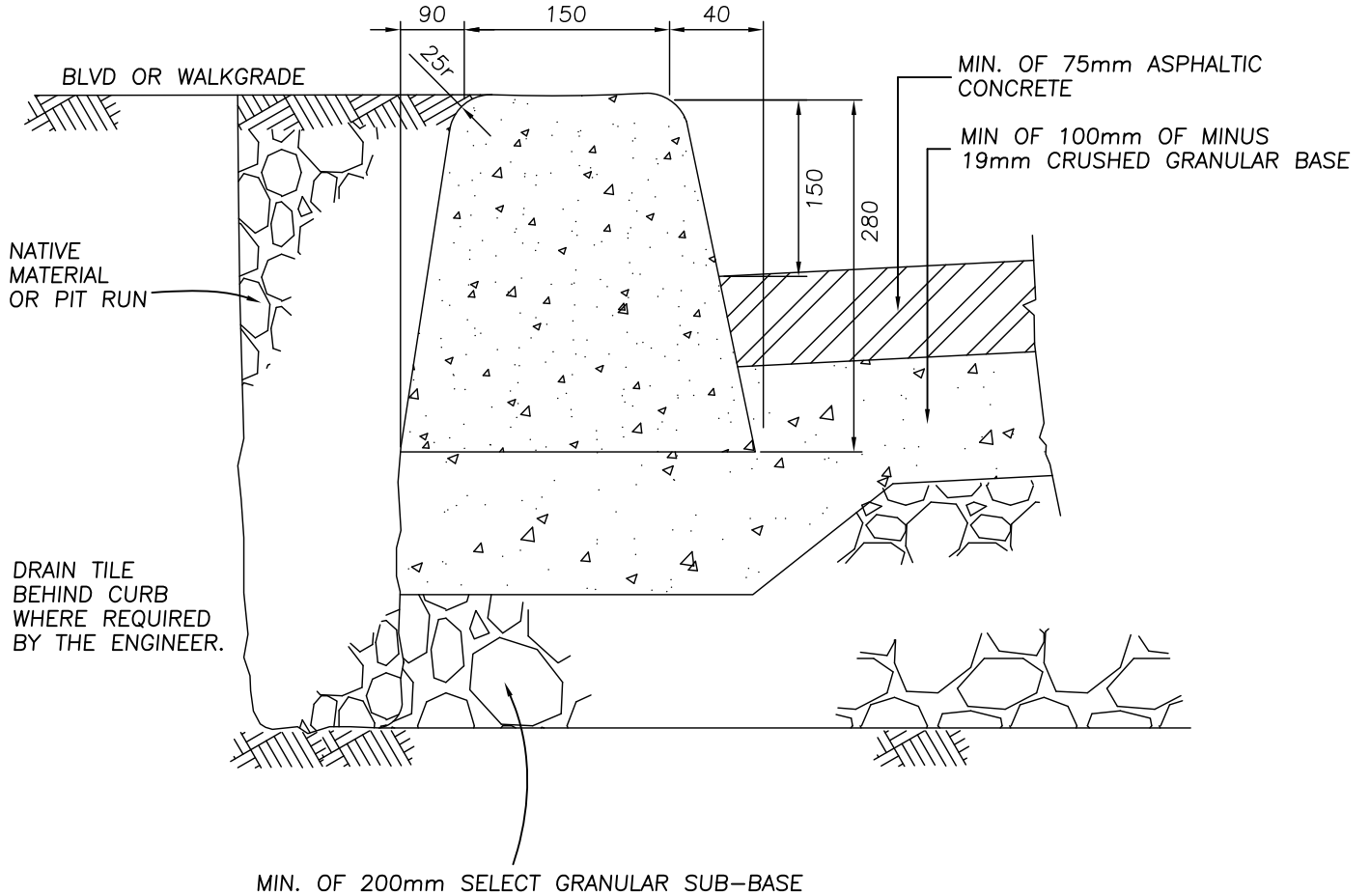

CURB ON GRAVEL BASE NO SIDEWALK

PLOTTED: 22-Feb-16

CURB ON GRAVEL BASE

DATE:	NOV/2015
DRAWN:	REY
SCALE:	N.T.S.

DRAWING NUMBER:  
**COQ-C6**

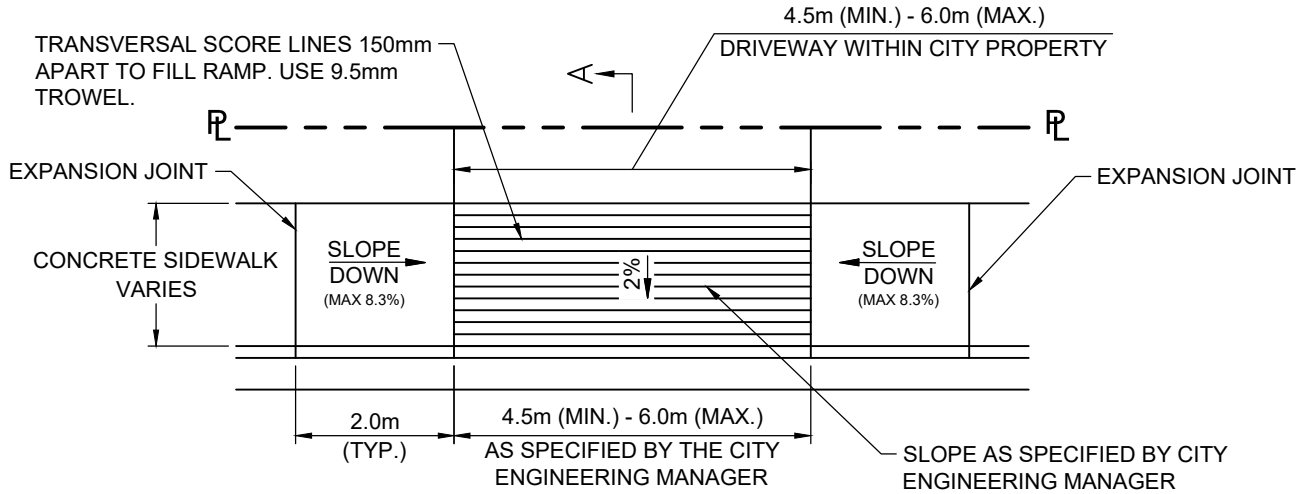

**PLAN VIEW**

**NOTES:**

1. WHERE DRIVEWAY IS AT LOWER GRADE THAN SIDEWALK, CROSSING SLOPES, BREAKOUT POINT AND D/W GRADE AS INDICATED BY DASHED LINE IN SECTION IF APPROVED BY THE CITY ENGINEERING MANAGER.
2. WHERE NEW CROSSING IS INSTALLED IN EXISTING SIDEWALK, BREAKOUT TO NEAREST TOOLED TRANSVERSE LINE.
3. WHERE SIDEWALK DOES NOT EXIST, DRIVEWAY MUST START AT TOP OF CURB RAMP AND EXTEND AT 45° TO A MAX WIDTH OF 6.0m ON CITY PROPERTY.
4. DRIVEWAY LETDOWN TO BE CENTRED ON GARAGE.
5. DRIVEWAY WIDTH ON CITY PROPERTY TO MATCH WIDTH OF LETDOWN EXCLUDING FLARES.
6. SLOPE DRIVEWAY AS SPECIFIED BY THE CITY ENGINEERING MANAGER.

SLAB THICKENS TO 190mm FOR ONE SIDEWALK PANEL PAST THE CURB RAMP

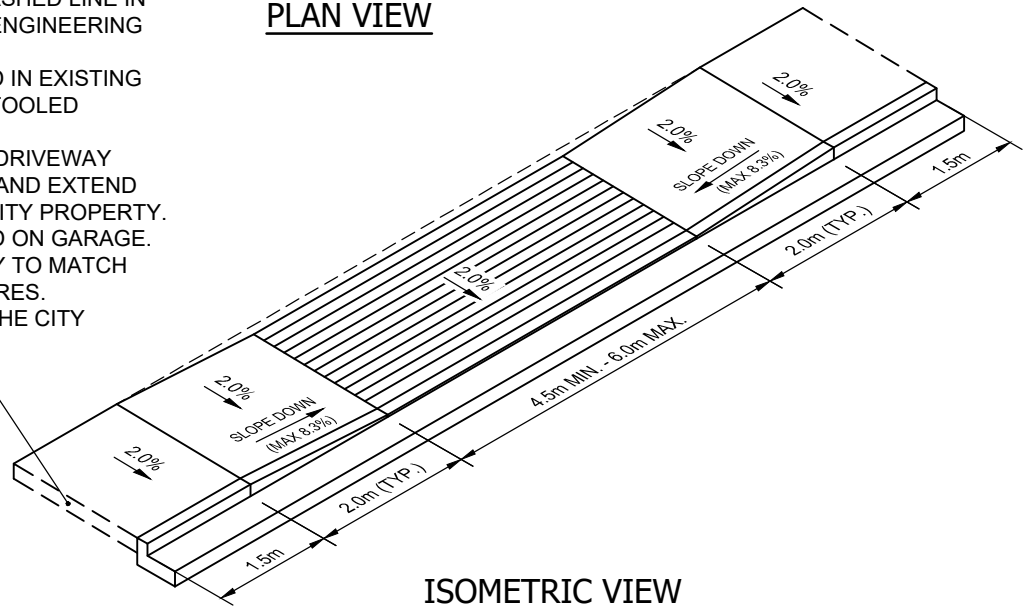

**ISOMETRIC VIEW**

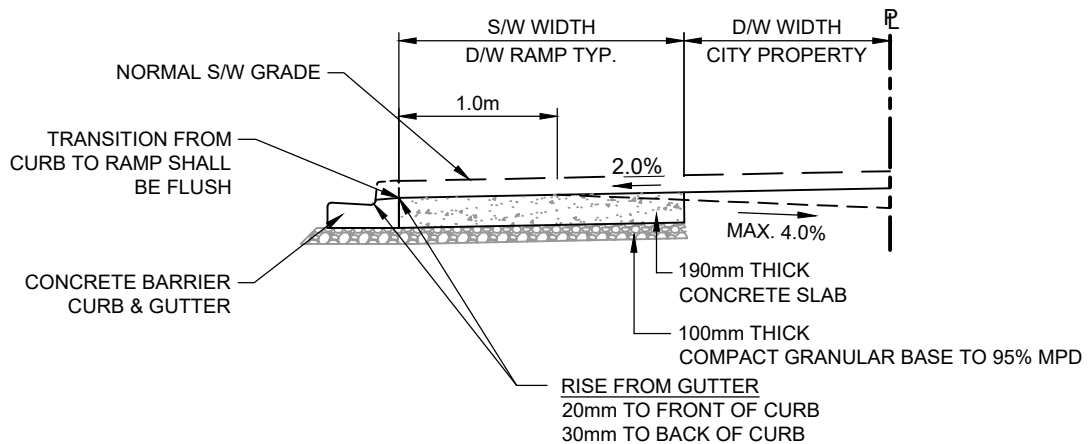

**SECTION A-A CURB RAMP**

PLOTTED: 19-NOV-20

**LOCAL, COLLECTOR  
DRIVEWAY CROSSING OF  
CURB, GUTTER AND SIDEWALK**

DATE: NOV/2020

DRAWN: GA

SCALE: N.T.S.

DRAWING NUMBER:

**COQ-C7**

ALL DIMENSIONS IN MILLIMETRES

$d$  = PIPE DIA IN mm

$H$  = TRENCH DEPTH IN mm

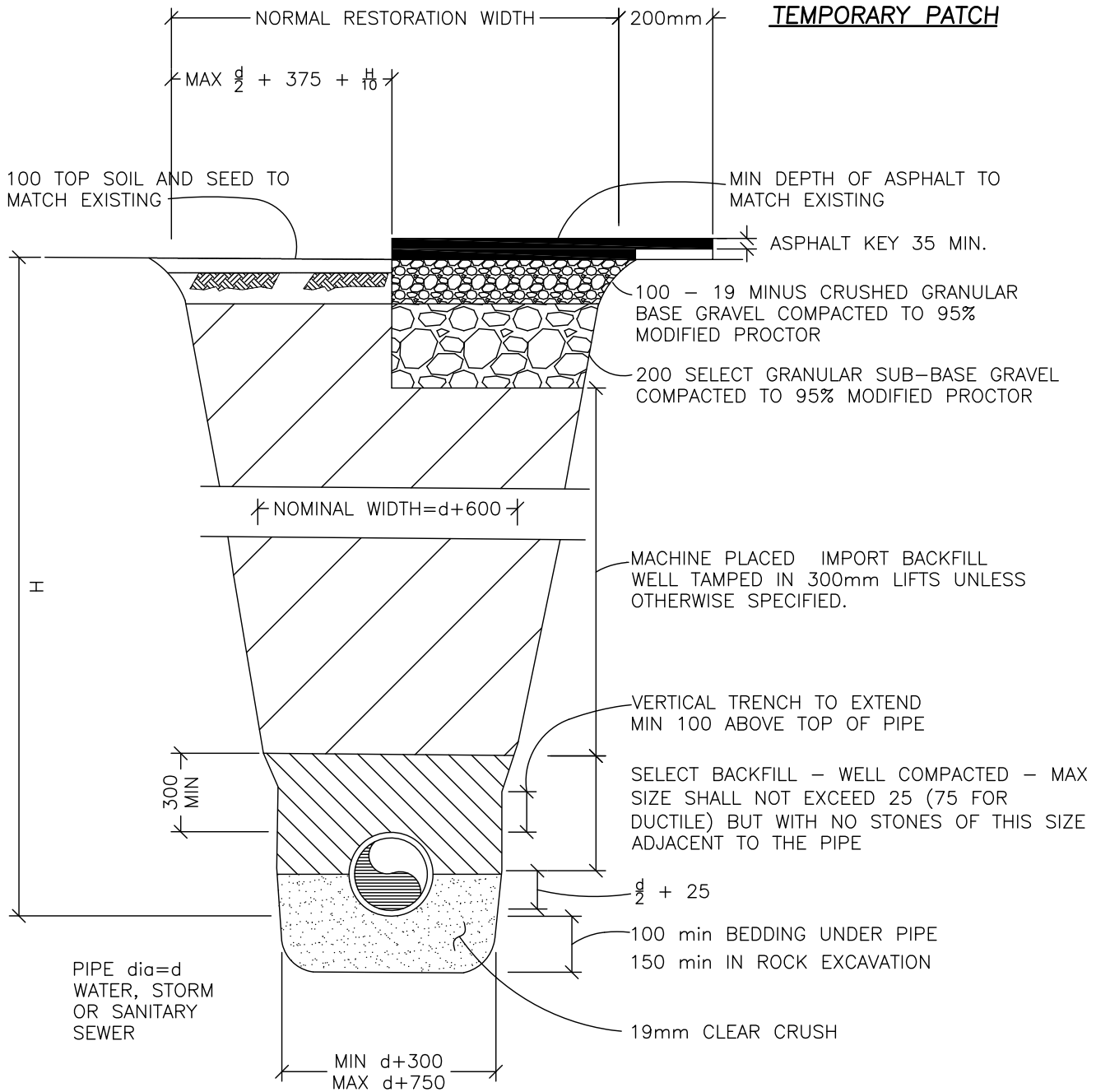
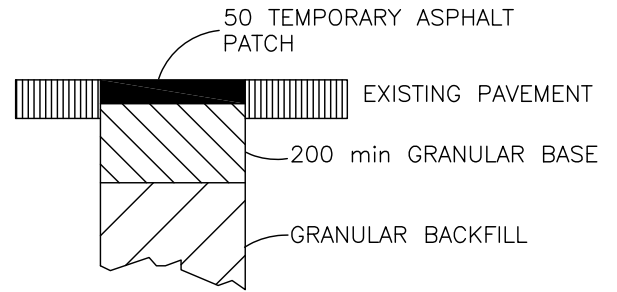

PLOTTED: 20-Sep-21

TRENCH DETAILS FOR STANDARD SECTION

DATE: AUG/2021

DRAWN: REY

SCALE: N.T.S.

DRAWING NUMBER:

COQ-G4

***Appendix E -  
Irrigation As-built  
Record Drawings***

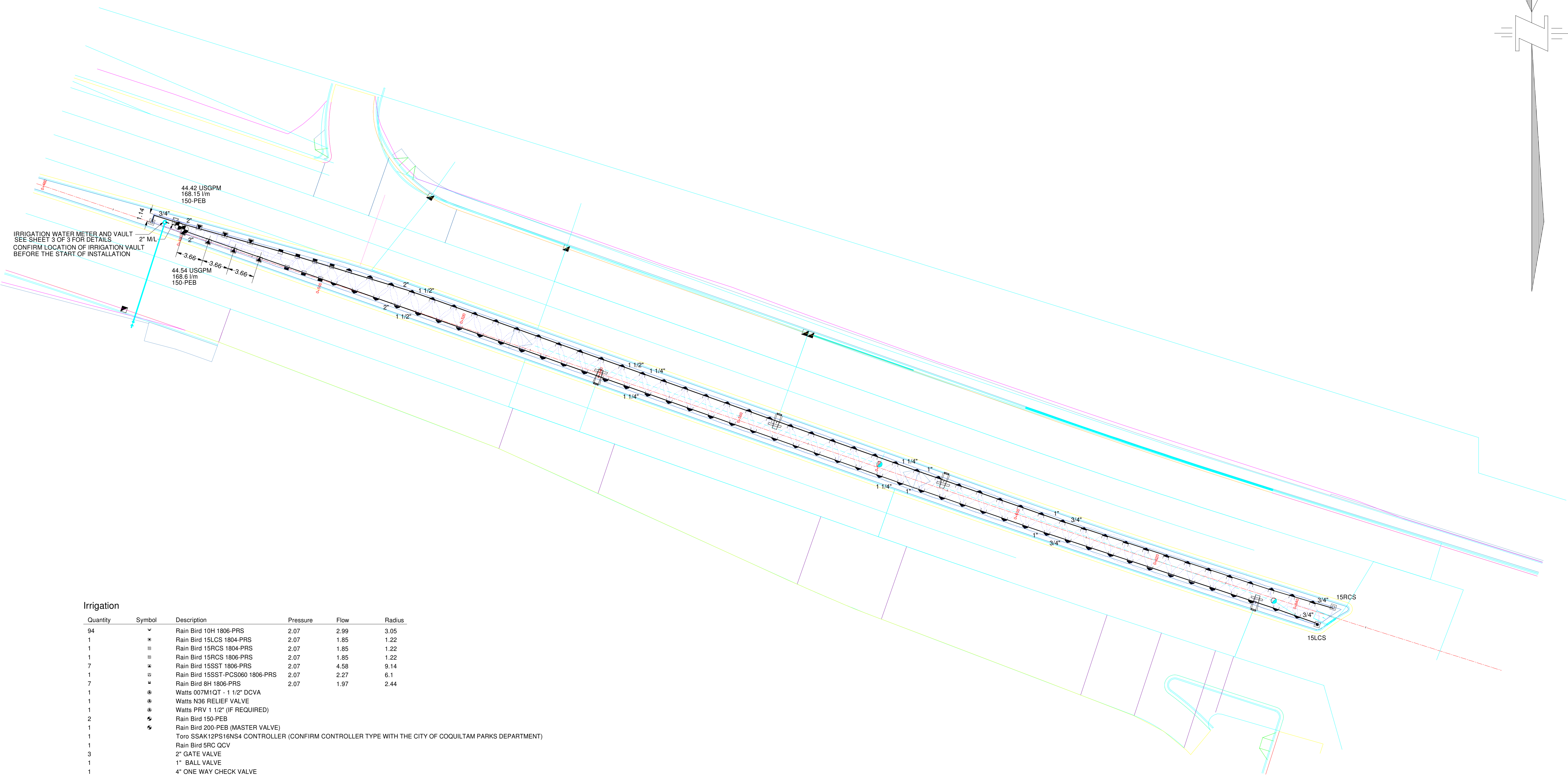
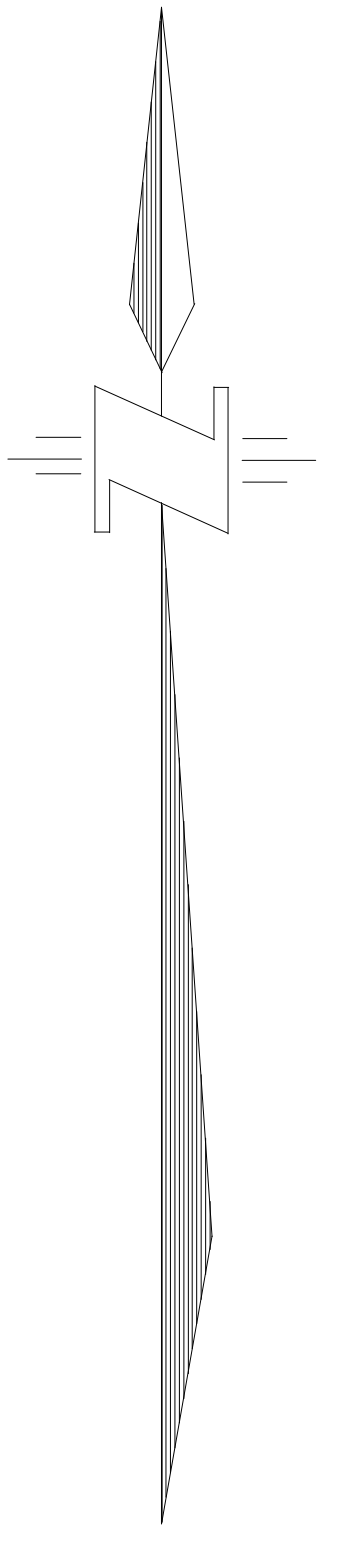

**Irrigation**

Quantity	Symbol	Description	Pressure	Flow	Radius
94	☐	Rain Bird 10H 1806-PRS	2.07	2.99	3.05
1	☐	Rain Bird 15LCS 1804-PRS	2.07	1.85	1.22
1	☐	Rain Bird 15RCS 1804-PRS	2.07	1.85	1.22
1	☐	Rain Bird 15RCS 1806-PRS	2.07	1.85	1.22
7	☐	Rain Bird 15SST 1806-PRS	2.07	4.58	9.14
1	☐	Rain Bird 15SST-PCS060 1806-PRS	2.07	2.27	6.1
7	☐	Rain Bird 6H 1806-PRS	2.07	1.97	2.44
1	⊙	Watts 007M1QT - 1 1/2\" DCVA			
1	⊙	Watts N36 RELIEF VALVE			
1	⊙	Watts PRV 1 1/2\" (IF REQUIRED)			
2	☐	Rain Bird 150-PEB			
1	☐	Rain Bird 200-PEB (MASTER VALVE)			
1		Toro SSAK12PS16NS4 CONTROLLER (CONFIRM CONTROLLER TYPE WITH THE CITY OF COQUITLAM PARKS DEPARTMENT)			
1		Rain Bird 5RC QCV			
3		2\" GATE VALVE			
1		1\" BALL VALVE			
1		4\" ONE WAY CHECK VALVE			
4		1419 VALVE BOX			
1		2\" DATA INDUSTRIAL FLOW SENSOR			
2		910 VALVE BOX			
5M	—	Class 160 2\" (SLEEVE)			
67M	—	Class 200 1 1/2\"			
80M	—	Class 200 1 1/4\"			
43M	—	Class 200 1\"			
66M	—	Class 200 2\"			
85M	—	Class 200 3/4\"			

SEE SHEET 3 OF 3 FOR NOTES AND IRRIGATION VAULT DETAIL

IRRIGATION DESIGN BY: <b>LUSH DESIGNS LTD.</b> 172 - 7251 - 140TH STREET SURREY, BC V3W 5J6 PH: 604 836-6405						DESTROY ALL PRINTS BEARING REV. NO. LESS THAN ONE INDICATED BELOW	
CITY OF COQUITLAM				Engineering & Public Works			
DESIGNED - CAL		DRAWN - CAL		METRIC SCALE - Horiz. 1:250		L.D.L. FILE No. 44 - 10	
CHECKED - CAL		DATE - AUG. 27, 2010		BETWEEN STNS 0+460 - 0+640		SHEET 2 OF 3	
REV. No. A		DATE AUG 27, 10		MEDIAN - IRRIGATION PLAN		REVISION A	